

Hall Effect Gear Tooth Speed and Direction Sensors CYGTS104U

Hall Effect Gear Tooth Sensor CYGTS104U uses two magnetically biased Hall Effect integrated circuits (ICs) to accurately sense movement of ferrous metal target (measuring) wheel. These specially designed integrated circuits, with bias magnet and discrete capacitor, are sealed in plastic package for physical protection and cost effective installation. The GTS IC works according to differential magnetic field detection.

This sensor functions under power supply from 4.5 to 24VDC. Two output signals are impulse, current sinking (open collector, NPN), which can be used for rotary speed measurement with direction detection. It has the advantage of reverse polarity protection. The sensor will not be damaged if power is inadvertently wired backwards.

Features

- Sensing ferrous metal target wheels
- Two impulse current sinking outputs NPN (OC) for speed measurement with direction detection
- Good signal-to-noise ratio
- Excellent low speed performance (0.1Hz)
- Output amplitude not dependent on RPM
- Fast operating speed, over 20kHz
- EMI resistant
- Reverse polarity protection and transient protection
- Wide operating temperature -40°~+135/150°C

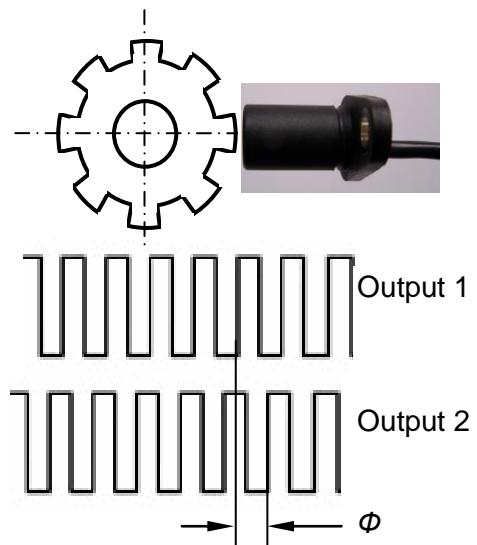

Applications

Automotive and Heavy Duty Vehicles:

- Camshaft and crankshaft speed and position
- Transmission speed
- Tachometers
- Anti-skid/traction control

Industrial Areas:

- Sprocket speed
- Chain link conveyor speed/distance
- Stop motion detector
- High speed low cost proximity
- Tachometers, counters.

Definition of Part Number:

Part number	Working temperature	Sensor case length	Distance between Hall ICs
CYGTS104U	-40°C ~ +135°C	36.4mm	5.4mm
CYGTS104UH	-40°C ~ +150°C		

Order Reference Number:

Order reference number = part number / cable length

For instance, CYGTS104U/1000mm is for sensor CYGTS104U with cable length 1m

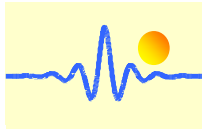

Absolute Maximum Ratings

Supply Voltage	-25V~+30V
Output Voltage	-0.7V~+30V (Output high)
Output Current	Sinking 50mA

Recommended Operating Conditions

Parameter	Conditions	Min	Typ	Max	Unit
Operating Temperature		-40		+135/+150	°C
Supply Voltage Vcc		4.5		24.0	V DC
Supply Current Icc		1	2.0	3.0	mA
Output Saturation Voltage Vsat	Low Output	≤0.50			V DC
High Output Voltage (Voh)		Voh ≥Vcc-0.5V			V
Frequency range		0.0001		20	kHz
Output Current	Low Output			20	mA
Output Leakage Current	High Output			10	µA
Rise Time (at load resistanc 2kΩ)				≤10.0	µs
Fall Time (at load resistanc 2kΩ)				≤10.0	µs

Block Diagram

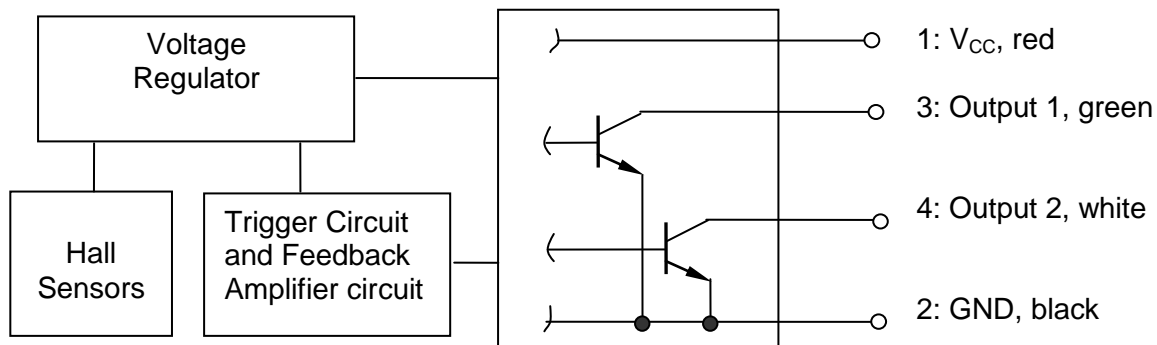

Connection

The output of the sensors is sinking current NPN (open collector). A pull-up resistor (2.5kΩ-15kΩ) should be connected to the sensor output circuit (between power supply Vcc and outputs). Please connect the pull-up resistors of both outputs before switching on the power supply.

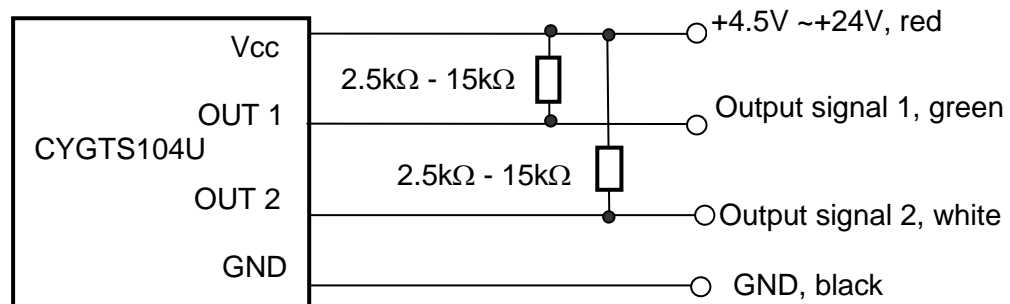

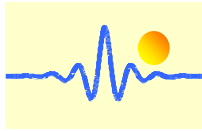

Differential Magnetic Field Detection

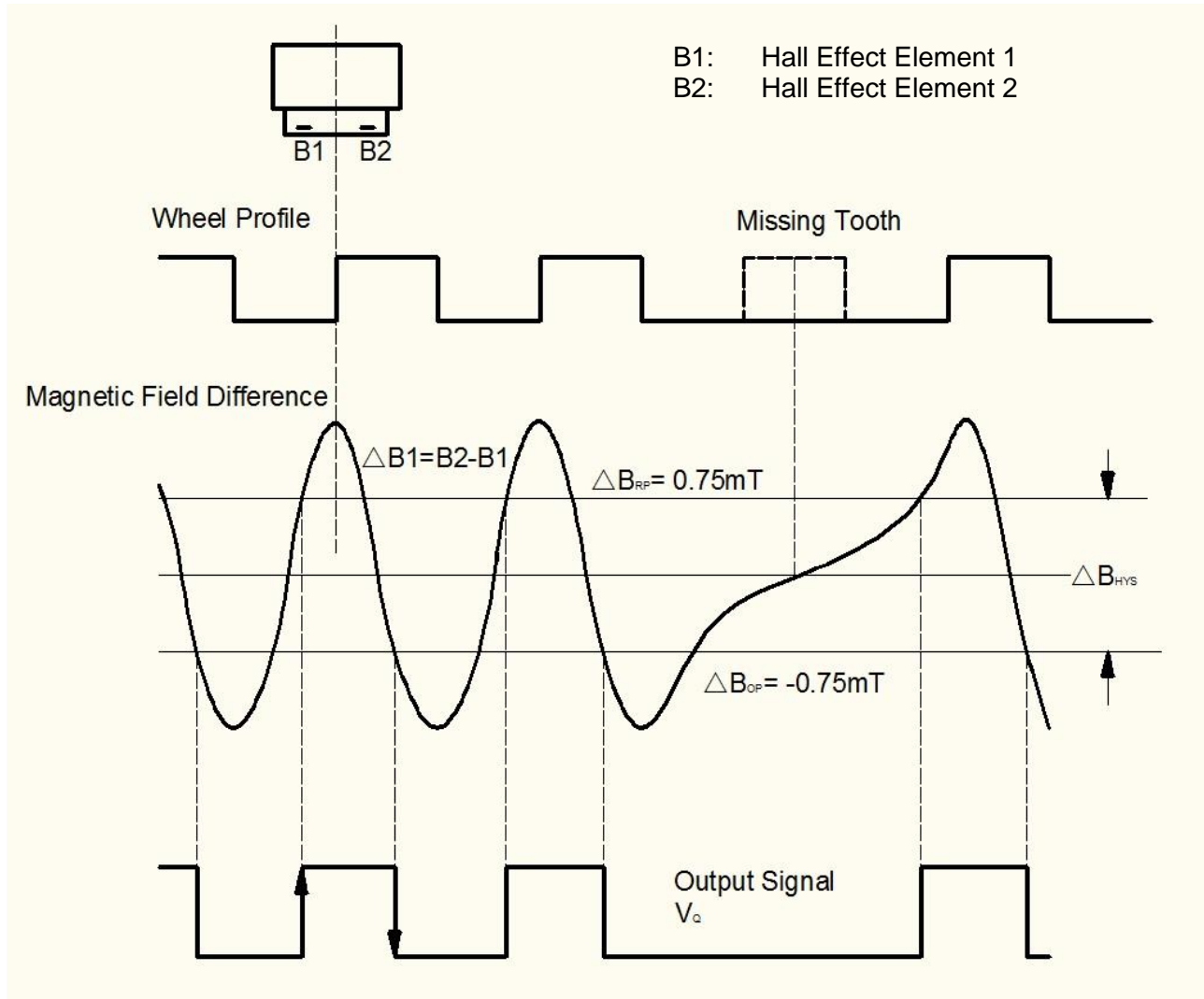

Operating point: $B_2 - B_1 < \Delta B_{OP}$ switches the output ON ($V_Q = \text{LOW}$)
Release point: $B_2 - B_1 > \Delta B_{RP}$ switches the output OFF ($V_Q = \text{HIGH}$)
 $\Delta B_{RP} = \Delta B_{OP} + \Delta B_{HYS}$

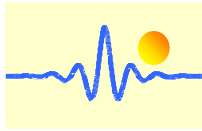

Sensor Position to Target (Measuring) Wheel

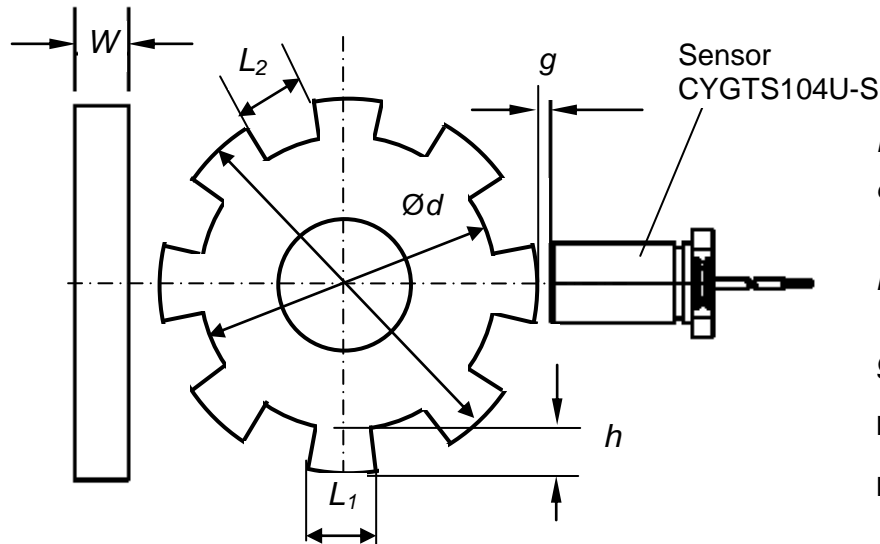

- D : Outside Diameter
- d : Root Diameter
- W : target thickness $\geq 5\text{mm}$
- h : Tooth height $\geq 3\text{mm}$
 $h = (D - d) / 2$
- g : Sensing Gap $\geq 0.1\text{mm}$
- $L1$: Tooth width
- $L2$: Tooth spacing

Reference Target Wheels and Sensing Gap (unit: mm)

Target wheel	Outer diameter	Tooth Height	Tooth Width	Tooth Spacing	Target Thickness	Teeth Number	Sensing Gap/distance
Target wheel 1	28	5.0	7.34	7.34	8.0	6	0.5-5.0
Target wheel 2	28	5.0	3.66	3.67	8.0	12	0.5-4.0
Target wheel 3	28	3.0	2.0	2.0	8.0	22	0.5-2.4
Target wheel 4	81.5	3.0	2.0	2.0	8.0	64	0.5-2.0

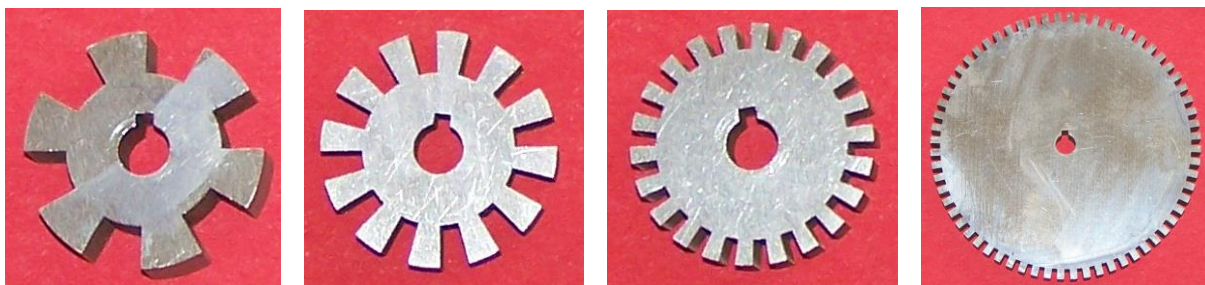

Characteristics will vary due to target size, geometry, location, and material. Optimum sensor performance is dependent on the following variables which must be considered in combination:

- Target material, geometry, and speed
- Gap between sensor and target
- Ambient temperature
- Magnetic material in close proximity.

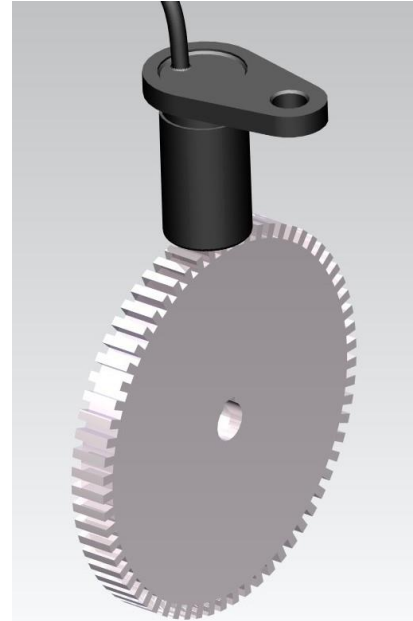
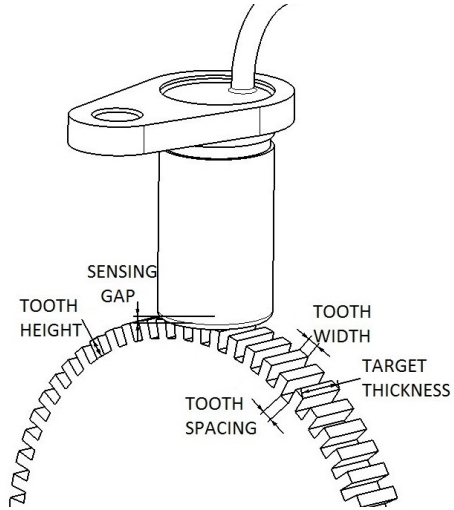
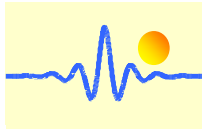

Mounting Dimensions (for reference only)

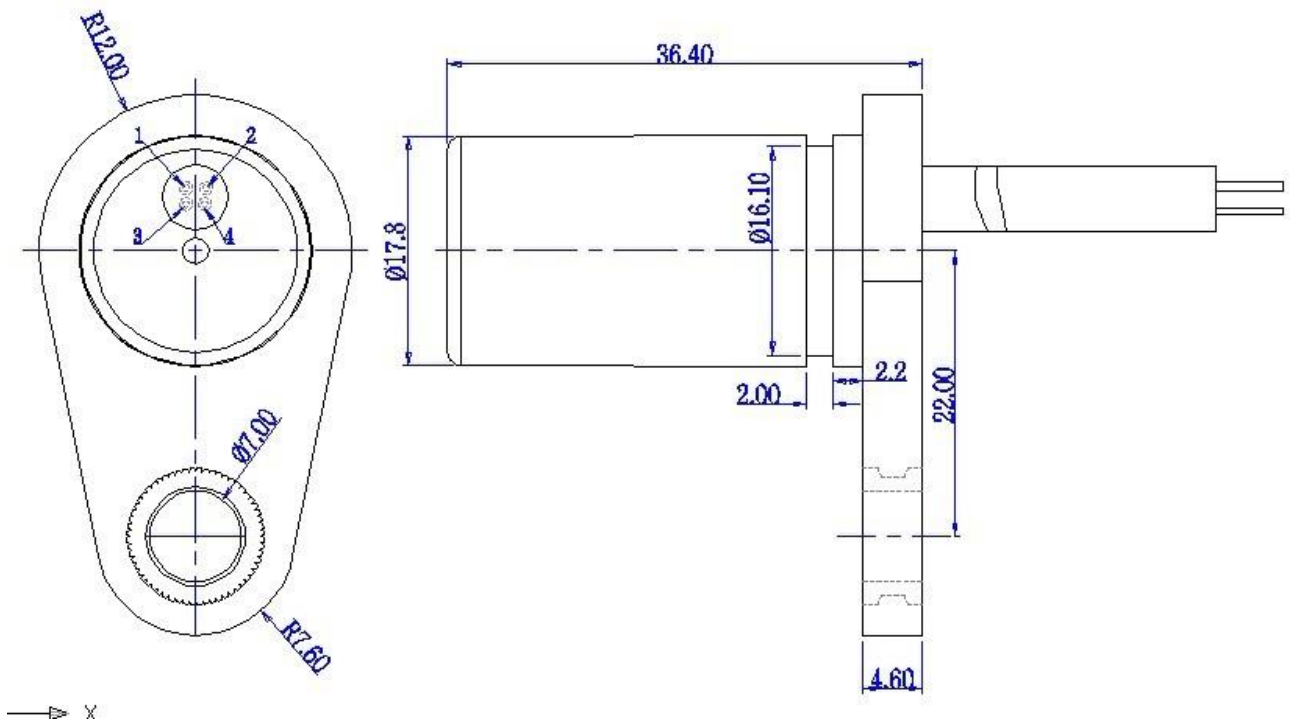

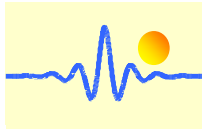

The standard length of the cable is 1.0m, diameter Ø4.0mm.

The length of cable is custom makeable.

Copyright© 2014, ChenYang Technologies GmbH & Co. KG

(This material is published on March 4, 2012, last revision on December 11, 2014)

All rights reserved. No part of this catalogue may be reproduced, stored in a retrieval system or transmitted in any form or by any means, electronic, mechanical, photocopying, recording or otherwise, without the prior permission of the copyright holder.

ООО Евросенсор

Россия
119071, г. Москва
ул. Малая Калужская,
д. 15, стр. 17, оф. 443

Тел: +7(495) 780-71-88
955-94-53

eurosensor@eurosensor.ru
www.eurosensor.ru