

Hall Effect Voltage Sensor CYHVS025A

CYHVS025A is a Hall Effect Voltage sensor, which is based on closed loop and magnetic compensation principle. This sensor can be used for measuring DC and AC voltage with different wave forms. It has high electric isolation.

Features

- High electrical isolation
- High reliability
- Good overload capability
- Small sizes
- Insulated plastic case recognized according to UL94-V0
- Very good property-price ratio

Applications

- Switched Mode Power Supplies
- Uninterruptible power supplies (UPS)
- Overvoltage protection
- Feedback of control systems
- Electric power network monitoring
- AC frequency conversion servo-motors
- Various power supplies
- Power supply for welding applications

Electrical Parameters

Parameters	Values			Unit
Rated input current (I_N)	± 10			mA
Measuring range (I_P)	0~ ± 14			mA
Rated measuring voltage	500			V
Max. measuring voltage	1000			V
Measuring resistance (R_M)		R_{Mmin}	R_{Mmax}	
	@ ± 10 mA	100	350	Ω
	@ ± 14 mA	100	190	Ω
Rated secondary current (I_S)	$\pm 25 \pm 0.5\%$			mA
Power supply (V_C)	$\pm 15 (\pm 5\%)$			V
Turns ratio (N)	2500 : 1000			
Current consumption (I_C)	15+ I_S			mA
Isolation voltage (V_d)	2.5kV/50Hz/1min			
Measuring accuracy (X_G)	$\pm 0.8\%$ FS, see application note			
Linearity (ϵ_L)	<0.2% FS			
Offset current (I_o)	± 0.1			mA
Thermal drift of offset current I_o (-40°C~+85°C)	± 0.5			mA
Response time (t_r)	<40			μs
Ambient operating temperature (T_A)	- 40°C ~ +85°C			
Ambient storage temperature (T_S)	-40°C ~ +125°C			
Primary coil resistance (R_p)	@ $T_a=25^\circ C$, 200			Ω
Secondary coil resistance (R_s)	@ $T_a=25^\circ C$, 110			Ω

Polarity: output current I_S is positive when input current I_P is applied on the "+" terminal

ООО Евросенсор

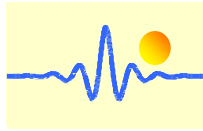

Case Style and Connection

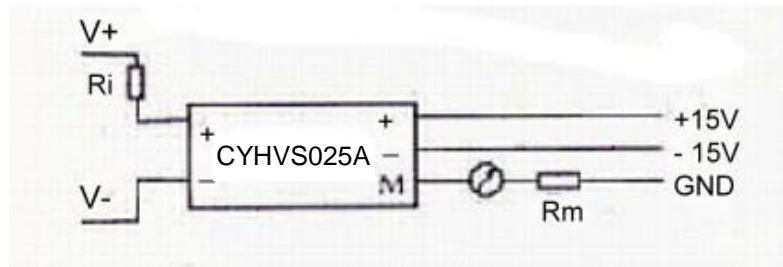
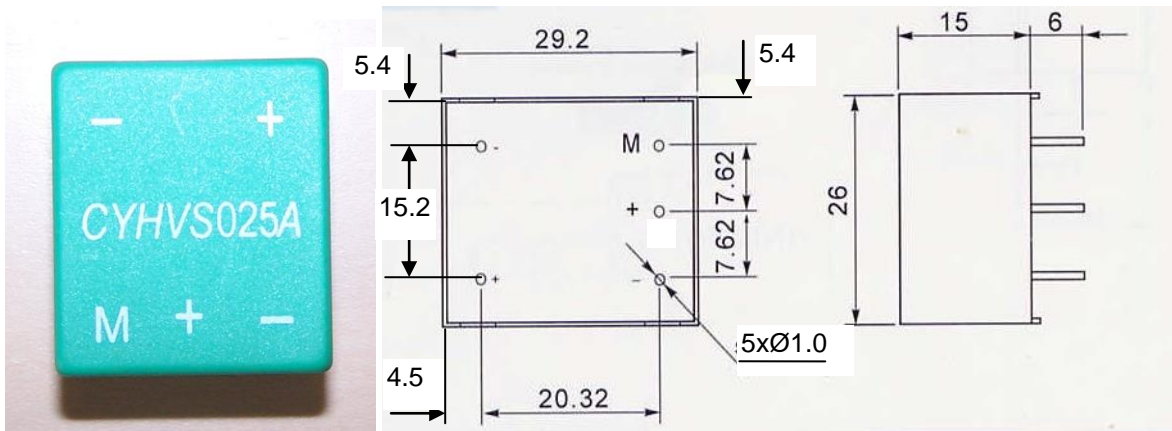

Measuring Principle

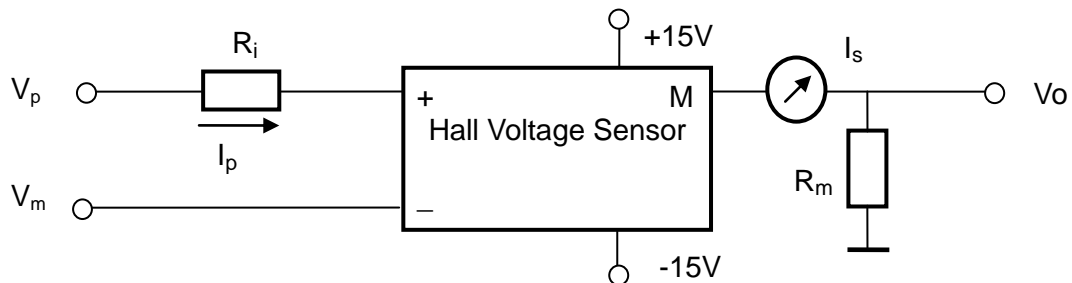

A magnetic field is generated by current I_p when a voltage ($V_p - V_m$) is applied on the input terminals of the sensor through the primary resistor R_i . This magnetic field is compensated with the reverse magnetic field caused by the current I_s in the secondary coil. The field compensation effect can be detected with a Hall Effect element. One obtains the following equation when the magnetic flux is zero:

$$N_p I_p = N_s I_s$$

where I_p : primary current; I_s : secondary current,
 N_p : primary turns, N_s : secondary turns.

The secondary current I_s is considered as output current of the sensor. Therefore the voltage ($V_p - V_m$) can be measured in this way under using the measuring resistor R_m .

ООО Евросенсор

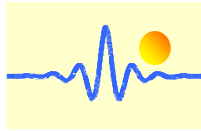

Application Note

1) Determination of Primary Resistor R_i

The primary resistor R_i should be selected to enable the rated input current to be equal to 10mA in order to obtain an optimal measuring accuracy.

For instance, the resistor R_i is 25k Ω for a rated input voltage of 250V. Here is recommended resistor in dependence of the measuring voltage:

Rated input voltage (V)	Resistor R_i (k Ω)
10	1
50	5
100	10
200	20
300	30
400	40
500	50

2) Measuring accuracy

The measuring accuracy depends on the input current. For instance, for measuring voltage of 250V, the accuracy is as follows:

Accuracy = $\pm 1.6\%$ ($T_a = +25^\circ\text{C}$)
Accuracy = $\pm 0.8\%$ ($T_a = +25^\circ\text{C}$)

$R_i = 50\text{k}\Omega/5\text{W}$, $I_P = 5\text{mA}$
 $R_i = 25\text{k}\Omega/10\text{W}$, $I_P = 10\text{mA}$

3) Measuring Range

The sensors are suitable for measuring a voltage 0 ~ $\pm 500\text{V}$. The primary resistor should be considered when selecting the measuring range in order to keep the temperature heating to a possible low level and to guarantee the high electric isolation property.

ООО Евросенсор

Россия
119071, г. Москва
ул. Малая Калужская,
д. 15, стр. 17, оф. 443

Тел: +7(495) 780-71-88
955-94-53

eurosensor@eurosensor.ru
www.eurosensor.ru