

User's guide

SFA-5000

SFA-10000

Absolute draw-wire encoder



lika

Smart encoders & actuators

This publication was produced by Lika Electronic s.r.l. 2015. All rights reserved. Tutti i diritti riservati. Alle Rechte vorbehalten. Todos los derechos reservados. Tous droits réservés.

This document and information contained herein are the property of Lika Electronic s.r.l. and shall not be reproduced in whole or in part without prior written approval of Lika Electronic s.r.l. Translation, reproduction and total or partial modification (photostat copies, film and microfilm included and any other means) are forbidden without written authorisation of Lika Electronic s.r.l.

The information herein is subject to change without notice and should not be construed as a commitment by Lika Electronic s.r.l. Lika Electronic s.r.l. reserves the right to make all modifications at any moments and without forewarning.

This manual is periodically reviewed and revised. As required we suggest checking if a new or updated edition of this document is available at Lika Electronic s.r.l.'s website. Lika Electronic s.r.l. assumes no responsibility for any errors or omissions in this document. Critical evaluation of this manual by the user is welcomed. Your comments assist us in preparation of future documentation, in order to make it as clear and complete as possible. Please send an e-mail to the following address info@lika.it for submitting your comments, suggestions and criticisms.

The logo for Lika Electronic s.r.l. consists of the word "lika" in a bold, lowercase, sans-serif font. The letters are black and set against a white background.

General contents



User's guide.....	1
General contents.....	3
Typographic and iconographic conventions.....	4
Preliminary information.....	5
1 Safety summary.....	6
1.1 Safety.....	6
1.2 Electrical safety.....	6
1.3 Mechanical safety.....	7
2 Identification.....	8
3 Mechanical installation.....	9
3.1 Overall dimensions.....	9
3.2 Mounting instructions.....	10
3.3 Useful information.....	11
3.4 Maintenance.....	12
4 Electrical connection.....	13
4.1 Cable and connectors connections.....	13
4.2 A8 cable specifications.....	13
4.3 M23 12-pin connector specifications.....	14
4.4 M12 8-pin connector specifications.....	14
4.5 Connection of the shield.....	14
4.6 Ground connection.....	15
4.7 Counting direction input.....	15
4.8 Zero setting input.....	15
5 SSI interface.....	18
5.1 SSI (Synchronous Serial Interface).....	18
5.2 "LSB Right Aligned" protocol.....	19
5.3 Recommended transmission rates.....	22
5.4 Max. speed and counting frequency.....	22
5.5 Recommended SSI circuit.....	24

Typographic and iconographic conventions

In this guide, to make it easier to understand and read the text the following typographic and iconographic conventions are used:

- parameters are coloured in **GREEN**;
- alarms are coloured in **RED**;
- states are coloured in **FUCSIA**.

Some icons in the pages are expressly designed to highlight the parts of the text which are of great interest and significance for the user. Sometimes they are used to warn against dangers or potential sources of danger arising from the use of the device. You are advised to follow strictly the instructions given in this guide in order to guarantee the safety of the user and ensure the performance of the device. In this guide the following symbols are used:

	This icon, followed by the word WARNING , is meant to highlight the parts of the text where information of great significance for the user can be found: user must pay the greatest attention to them! Instructions must be followed strictly in order to guarantee the safety of the user and a correct use of the device. Failure to heed a warning or comply with instructions could lead to personal injury and/or damage to the unit or other equipment.
	This icon, followed by the word NOTE , is meant to highlight the parts of the text where important notes needful for a correct and reliable use of the device can be found. User must pay attention to them! Failure to comply with instructions could cause the equipment to be set wrongly: hence a faulty and improper working of the device could be the consequence.
	This icon is meant to highlight the parts of the text where suggestions useful for making it easier to set the device and optimize performance and reliability can be found. Sometimes this symbol is followed by the word EXAMPLE when instructions for setting parameters are accompanied by examples to clarify the explanation.

Preliminary information

This guide is designed to provide the most complete and exhaustive information the operator needs to correctly and safely install and operate the **SFA-5000 and SFA-10000 absolute draw-wire encoders**. SFA-5000/SFA-10000 cable-pulling encoder is aimed at speed and position measurements and controls in a variety of industrial applications through the movement of a **5,000 mm (196.85") or 10,000 mm (393.7")** stainless steel wire. The typical back and forth travel of the moving equipment causes the wire to reel and unreel and thus the linear movement to be converted into a rotative motion detected by the encoder which is coupled to the drum.

SFA-5000/SFA-10000 provides the absolute position information through the "LSB Right Aligned" protocol SSI interface.

To make it easier to read and understand the text, this guide is divided into two main sections.

In the first section some general information concerning the safety, the mechanical installation and the electrical connection as well as tips for setting up and running properly and efficiently the SFA-5000/SFA-10000 cable-actuated encoder are provided.

In the second section, entitled **SSI Interface**, you can find detailed information on the SSI interface.

1 Safety summary



1.1 Safety

- Always adhere to the professional safety and accident prevention regulations applicable to your country during device installation and operation;
- installation and maintenance operations have to be carried out by qualified personnel only, with power supply disconnected and stationary mechanical parts;
- device must be used only for the purpose appropriate to its design: use for purposes other than those for which it has been designed could result in serious personal and/or the environment damage;
- high current, voltage and moving mechanical parts can cause serious or fatal injury;
- warning ! Do not use in explosive or flammable areas;
- failure to comply with these precautions or with specific warnings elsewhere in this manual violates safety standards of design, manufacture, and intended use of the equipment;
- Lika Electronic s.r.l. assumes no liability for the customer's failure to comply with these requirements.



1.2 Electrical safety

- Turn OFF power supply before connecting the device;
- connect according to explanation in the "Electrical connection" section;
- connect Zero setting input to 0Vdc, if not used; to zero set the encoder, connect Zero setting to +Vdc for 100 μ s at least, then disconnect +Vdc; normally voltage must be at 0Vdc; zero set must be performed after Counting direction; we suggest performing the zero set when the encoder is in stop;
- connect Counting direction input to 0Vdc, if not used; to have the count up when pulling the wire out = connect the input to 0Vdc; to have the count up when rewinding the wire = connect to +Vdc;
- in compliance with 2004/108/EC norm on electromagnetic compatibility, following precautions must be taken:
 - before handling and installing the equipment, discharge electrical charge from your body and tools which may come in touch with the device;
 - power supply must be stabilized without noise; install EMC filters on device power supply if needed;
 - always use shielded cables (twisted pair cables whenever possible);



- avoid cables runs longer than necessary;
- avoid running the signal cable near high voltage power cables;
- mount the device as far as possible from any capacitive or inductive noise source; shield the device from noise source if needed;
- to guarantee a correct working of the device, avoid using strong magnets on or near by the unit;
- minimize noise by connecting the shield and/or the connector housing and/or the frame to ground. Make sure that ground is not affected by noise. The connection point to ground can be situated both on the device side and on user's side. The best solution to minimize the interference must be carried out by the user.



1.3 Mechanical safety

- Install the device following strictly the information in the "Mechanical installation" section;
- mechanical installation has to be carried out with stationary mechanical parts;
- do not disassemble the unit;
- do not tool the unit;
- delicate electronic equipment: handle with care; do not subject the device to knocks or shocks;
- respect the environmental characteristics of the product;
- we suggest installing the unit providing protection means against waste, especially swarf as turnings, chips, or filings; should this not be possible, please make sure that adequate cleaning measures are in place in order to prevent the wire from jamming;
- to avoid failures, never exceed the maximum measuring length and prevent the wire from tangling up;
- never release the wire freely, always help the wire wind properly: risk of personal injury and/or equipment damage;
- always keep the wire aligned not to damage the equipment;
- the stroke per turn of the draw-wire unit is 200 mm (7.874").

2 Identification

Device can be identified through the **order code** and the **serial number** printed on the label applied to its body. Information is listed in the delivery document too. Please always quote the order code and the serial number when reaching Lika Electronic. For any information on the technical characteristics of the product refer to the technical catalogue.



Warning: encoders having order code ending with "/Sxxx" may have mechanical and electrical characteristics different from standard and be supplied with additional documentation for special connections (Technical Info).

3 Mechanical installation



WARNING

Installation has to be carried out by qualified personnel only, with power supply disconnected and mechanical parts compulsorily in stop.

3.1 Overall dimensions

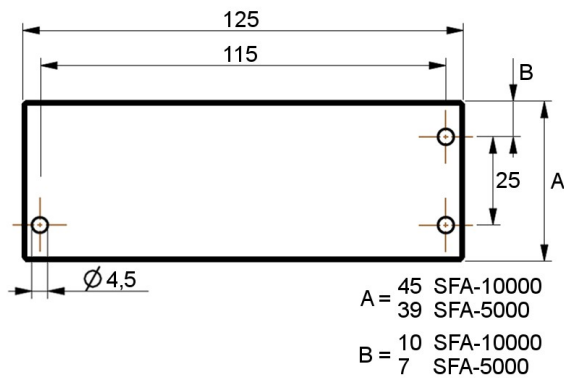
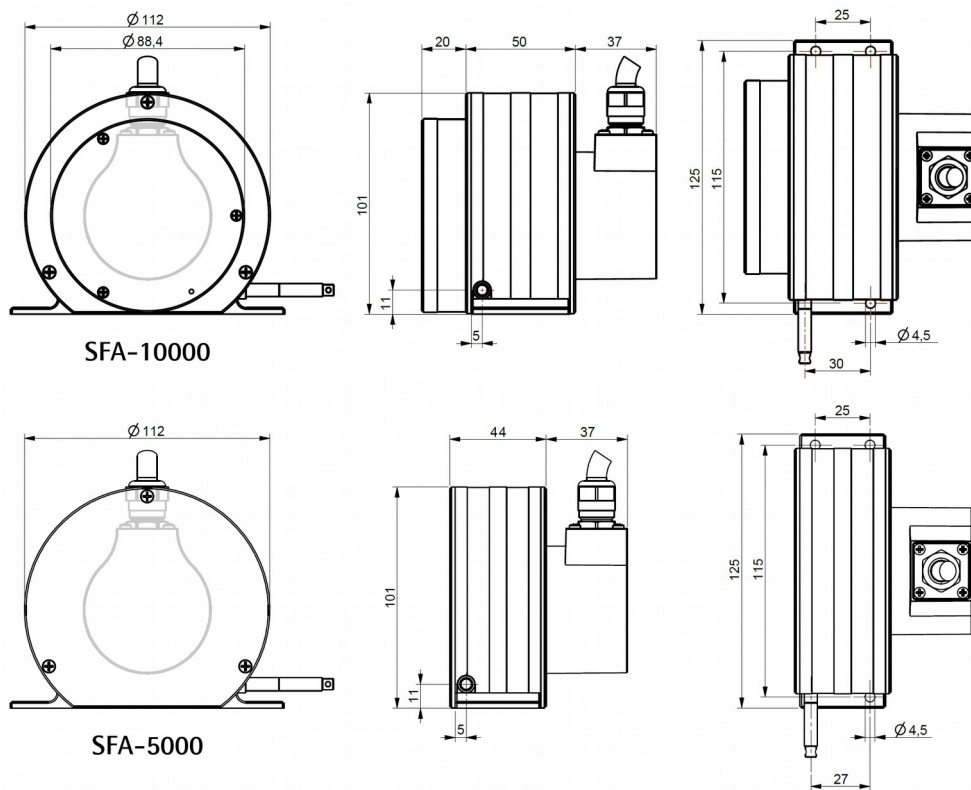

Values are expressed in mm

3.2 Mounting instructions

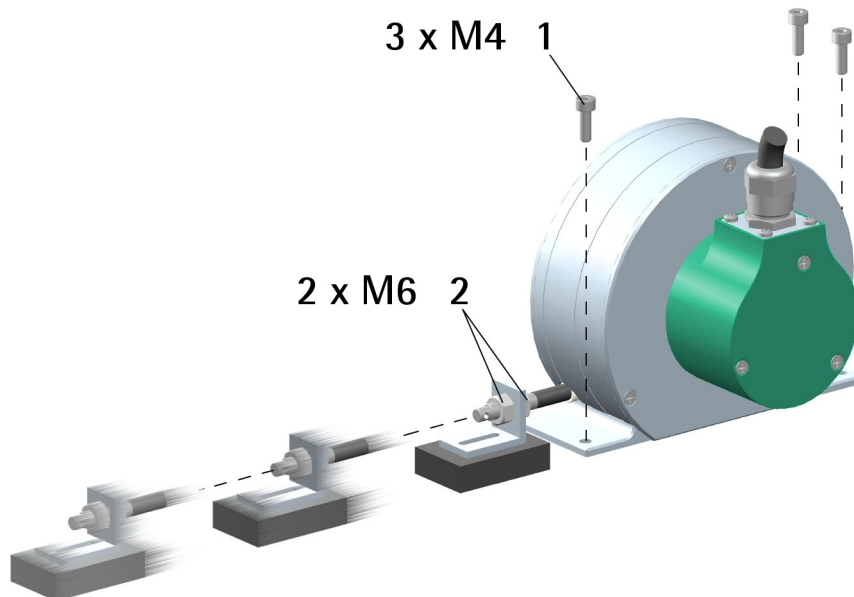

- Fasten the draw-wire unit onto a fixed support using three M4 screws **1**;
- remove the transport safety wire that pins the end of the measuring wire;
- fix the end of the measuring wire to the moving unit using the provided M6 nuts **2**.



WARNING

We suggest installing the unit providing protection means against waste, especially swarf as turnings, chips, or filings; should this not be possible, please make sure that adequate cleaning measures are in place in order to prevent the wire from jamming.

To avoid irreparable failures, never exceed the maximum measuring length and prevent the wire from tangling up.

Never release the wire freely, always help the wire wind properly: risk of personal injury and/or equipment damage.

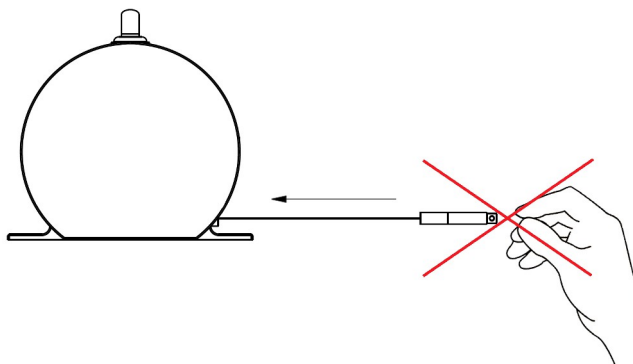

Always keep the wire aligned not to damage the equipment (maximum deviation: 3°).

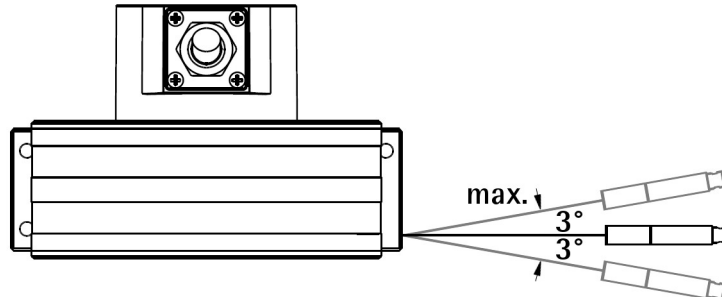

3.3 Useful information

If you want to know the **maximum measuring length** and the **resolution** of the draw-wire encoder please refer to the order code. The stroke per turn is always 200 mm (7.874"), the maximum number of turns is 25 for SFA-5000 and 50 for SFA-10000.



EXAMPLE 1

SFA-5000-GA-8192-L1

Stroke per turn = 200 mm (7.874")

Resolution per turn = 8,192 CPR

Max. number of encoder revolutions = 4,096

Linear resolution = 0.024 mm = 24 μm

Max. number of turns = 25

Max. measuring length = 5,000 mm (196.85")

Number of information = 204,800

Interface = SSI "LSB Right Aligned", Gray code



EXAMPLE 2

SFA-10000-BA-2000-RM2

Stroke per turn = 200 mm (7.874")

Resolution per turn = 2,000 CPR

Max. number of encoder revolutions = 4,096

Linear resolution = 0.1 mm = 100 μm

Max. number of turns = 50

Max. measuring length = 10,000 mm (393.7")

Number of information = 100,000

Interface = SSI "LSB Right Aligned", Binary code

3.4 Maintenance

The measuring system does not need any particular maintenance; anyway it has to be handled with the utmost care as any delicate electronic equipment. From time to time we recommend the following operations:

- the unit and the wire have to be cleaned regularly using a soft and clean cloth to remove dust, chips, moisture etc.; do not use oil to clean the wire.

4 Electrical connection



WARNING

Electrical connection has to be carried out by qualified personnel only, with power supply disconnected and mechanical parts compulsorily in stop.

4.1 Cable and connectors connections

Function	A8 cable	M23 12-pin	M12 8-pin
Clock IN +	White	2	3
Clock IN -	Brown	1	4
Data OUT +	Green	3	5
Data OUT -	Yellow	4	6
Counting direction	Blue	8	8
Zero setting	Pink	9	7
0Vdc	Black	12	1
+7.5Vdc +34Vdc	Red	11	2
Shielding	Shield	Case	Case

4.2 A8 cable specifications

Model	: LIKA SSI A8 cable
Cross section	: 4 x 2 x 0.25 mm ² (24 AWG)
Jacket	: flame retardant PVC
Shield	: tinned copper braid, coverage ≥ 75%
Outer diameter	: 7.0 ± 0.15 mm (0.276" ± 0.006")
Min. bending radius	: 15 mm (0.59")
Work temperature	: -15°C +80°C (+5°F +176°F)
Conductor resistance	: ≤ 78.5 Ω/km

4.3 M23 12-pin connector specifications

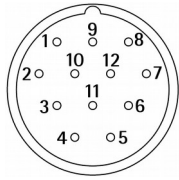

M23 12-pin connector
Male
Counter-clockwise

4.4 M12 8-pin connector specifications

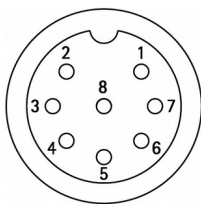

Male
Frontal side
A coding

4.5 Connection of the shield

For signals transmission always use shielded cables. The cable shielding must be connected properly to the metal ring nut **3** of the connector in order to ensure a good earthing through the frame of the device. To do this disentangle and shorten the shielding **1** and then bend it over the part **2**; finally place the ring nut **3** of the connector. Be sure that the shielding **1** is in tight contact with the ring nut **3**.

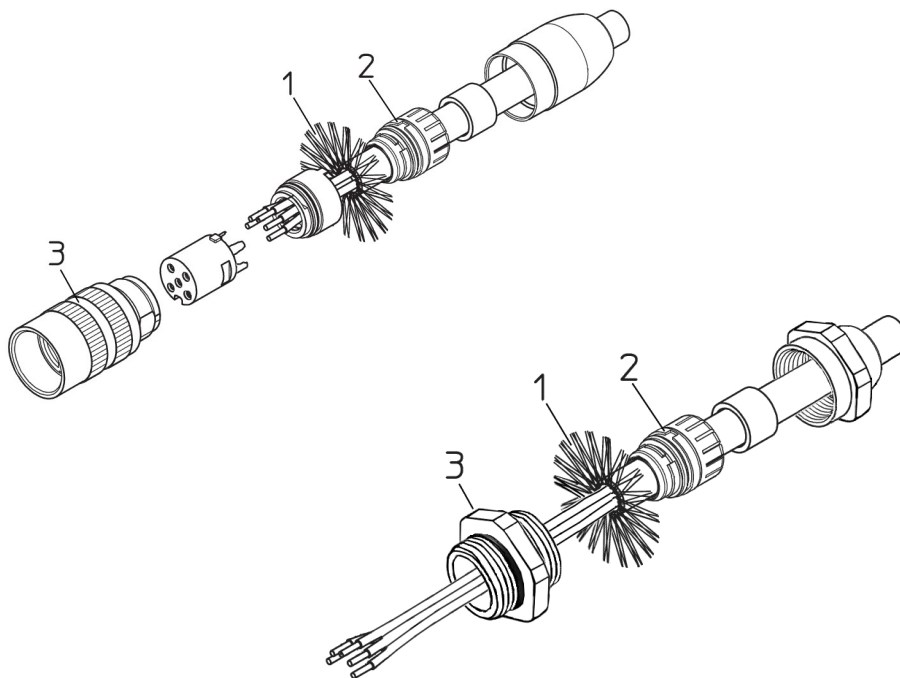

4.6 Ground connection

Minimize noise by connecting the shield and/or the connector housing and/or the frame to ground. Make sure that ground is not affected by noise. The connection point to ground can be situated both on the device side and on user's side. The best solution to minimize the interference must be carried out by the user. You are advised to provide the ground connection as close as possible to the encoder.

4.7 Counting direction input

The counting direction circuit allows to reverse the counting direction. The **standard counting direction** (count up information) is to be intended when pulling the wire out. This input allows the count up when rewinding the wire. Connect the counting direction input to 0Vdc to have an increasing count when pulling the wire out; connect the counting direction input to +Vdc to have an increasing count when rewinding the wire. Connect the Counting direction input to 0Vdc if not used.



WARNING

After having set the new counting direction it is necessary to zero set the encoder position.

Positive counting direction

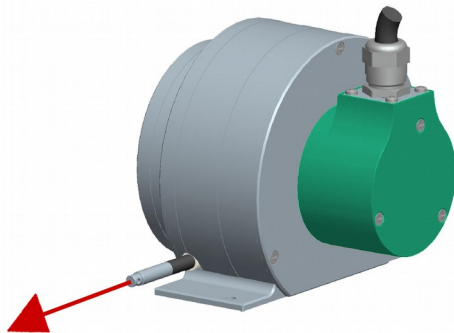

Inverted counting direction

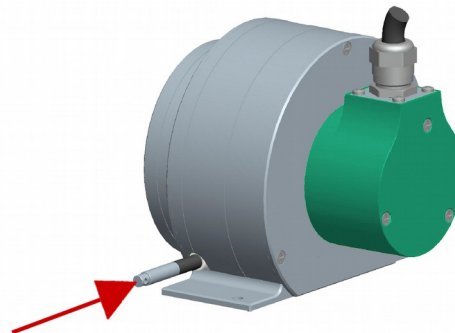

Positive counting direction (count up information) when pulling the wire out

4.8 Zero setting input

The output value can be set to zero (reset) via an external signal issued by a PLC or other controller device. When the internal microprocessor receives the signal it resets the output information. This can be very useful for setting the zero

position of both the encoder and the machine. To zero set the encoder, connect Zero setting input to +Vdc for 100 μ s at least, then disconnect +Vdc; normally voltage must be at 0Vdc; zero set must be performed after Counting direction setting; we suggest performing the zero set when the encoder is in stop. Connect the Zero setting input to 0Vdc if not used.



NOTE

Please note that, after setting the zero point, the positive counting will be from 0 towards the max. value (see the table below); if you move the axis before the 0 point, the detected value will be the max. number of information - 1 down.



EXAMPLE

Let's suppose we are using the SFA-5000-xx-8192-... model; the encoder is set to have the positive counting when pulling the cable out (see the Figure below). If you set the 0 along the path, starting from the 0 point, the output values will be from 0 towards the max. value (204,800, see the table below) when you pull out the cable; when the encoder moves back and cross the zero, the value immediately after 0 will be the max. number of information - 1 (33,554,431).

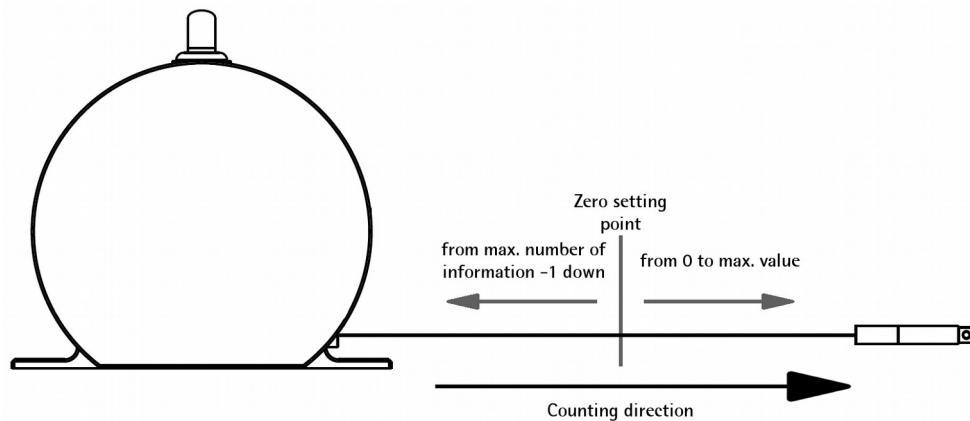

...	33554430	33554431	0	1	2	...	204800
-----	----------	----------	---	---	---	-----	--------

Model	Max. value	Max. number of information
SFA-5000-xx-8192-...	204,800	25 bits (33,554,432)
SFA-10000-xx-8192-...	409,600	
SFA-5000-xx-4000-...	100,000	24 bits (16,384,000)
SFA-10000-xx-4000-...	200,000	

SFA-5000-xx-2000-...	50,000	23 bits (8,192,000)
SFA-10000-xx-2000-...	100,000	

5 SSI interface

Order code: SFA-xxxxx-BA-...
SFA-xxxxx-GA-...

5.1 SSI (Synchronous Serial Interface)



SSI (the acronym for **Synchronous Serial Interface**) is a synchronous point-to-point serial interface engineered for unidirectional data transmission between one Master and one Slave. Developed in the first eighties, it is based on the RS-422 serial standard. Its most peculiar feature is that data transmission is achieved by synchronizing both the Master and the Slave devices to a common clock signal generated by the controller; in this way the output information is clocked out at each controller's request. Furthermore only two pairs of twisted wires are used for data and clock signals, thus a six-wire cable is required. The main advantages in comparison with parallel or asynchronous data transmissions are:

- less conductors are required for transmission;
- less electronic components;
- possibility of insulating the circuits galvanically by means of optocouplers;
- high data transmission frequency;
- hardware interface independent from the resolution of the absolute encoder.

Furthermore the differential transmission increases the noise immunity and decreases the noise emissions. It allows multiplexing from several encoders, thus process controls are more reliable with simplified line design and easier data management.

Data transmission is carried out as follows.

At the first falling edge of the clock signal (**1**, the logic level changes from high to low) the absolute position value is stored while at the following rising edge (**2**) the transmission of data information begins starting from the MSB.

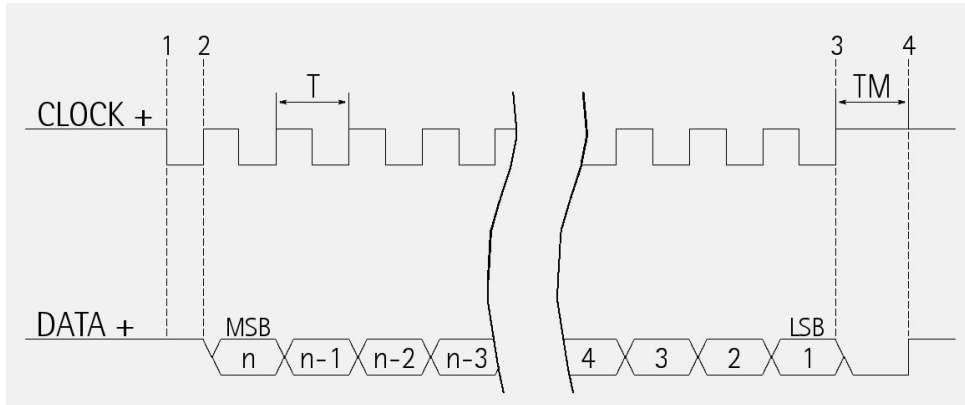

At each change of the clock signal and at each subsequent rising edge (2) one bit is clocked out at a time, up to LSB, so completing the data word transmission. The cycle ends at the last rising edge of the clock signal (3). This means that up to $n + 1$ rising edges of the clock signals are required for each data word transmission (where n is the bit resolution); for instance, a 13-bit encoder needs 14 clock edges. If the number of clocks is greater than the number of bits of the data word, then the system will send a zero (low logic level signal) at each additional clock, zeros will either lead (LSB ALIGNED protocol) or follow (MSB ALIGNED protocol) or lead and/or follow (TREE FORMAT protocol) the data word. After the period T_m monoflop time, having a typical duration of 16 μsec , calculated from the end of the clock signal transmission, the encoder is then ready for the next transmission and therefore the data signal is switched high.

The clock signal has a typical logic level of 5V, the same as the output signal which has customarily a logic level of 5V in compliance with RS-422 standard. The output code can be either Binary or Gray (see the order code).

5.2 "LSB Right Aligned" protocol

"LSB Right Aligned" protocol allows to right align the bits, beginning from MSB (most significant bit) to LSB (least significant bit); LSB is then sent at the last clock cycle. If the number of clock signals is higher than the data bits, then unused bits are forced to logic level low (0) and lead the data word. This protocol can be used in encoders having any resolution.

The word is 25-bit long, unused bits are set to 0 (zero).

Thus it will be as follows:

Model	Counts per revolution	Information per mm	Resolution	Length of the word	Max. number of information
SFA-5000-xx-8192-...	8,192	41.66	0.024 mm	25 bits	25 bits (33,554,432)
SFA-10000-xx-8192-...					
SFA-5000-xx-4000-...	4,000	20	0.05 mm	25 bits	24 bits (16,384,000)
SFA-10000-xx-4000-...					
SFA-5000-xx-2000-...	2,000	10	0.1 mm	25 bits	23 bits (8,192,000)
SFA-10000-xx-2000-...					

The output code can be GRAY or BINARY (see the order code).
The length of the measuring step is equal to the resolution.

Structure of the transmitted position value:

SFA-xxxxx-xx-8192	bit	25	...	1	
	value	MSB	...	LSB	
SFA-xxxxx-xx-4000	bit	25	24	...	1
	value	0	MSB	...	LSB
SFA-xxxxx-xx-2000	bit	25 - 24	23	...	1
	value	00	MSB	...	LSB



WARNING

Please note that the position value issued by the encoder is expressed in pulses; thus you have then to convert the number of pulses into a linear measuring unit.

To convert the position value into millimetres (mm) or micrometres (µm) you have to multiply the number of information by the linear resolution of the encoder expressed in millimetres or micrometres.

To know the linear resolution of the encoder please consider that **the stroke per turn is 200 mm**.

The linear resolution results from the following calculation:

$$\text{Linear resolution} = \frac{\text{Stroke per turn}}{\text{Resolution CPR}}$$

If you want then to know the linear position value you will need to multiply the transmitted position value by the linear resolution.

Linear position value = transmitted position * linear resolution



NOTE

Please note that the encoder's linear resolution can be read also in the order code next to the rotary resolution. Refer to the product datasheet.



EXAMPLE 1

Let's suppose that we are using the SFA-5000-BA-8192-... draw-wire encoder. The resolution of the measuring device is 8,192 CPR (= 0.024 mm, see the order code in the product datasheet).

As stated, the linear resolution results from the following calculation:

$$\text{Linear resolution} = \frac{\text{Stroke per turn}}{\text{Resolution CPR}}$$

$$\text{Linear resolution} = \frac{200}{8192} = 0.024 \text{ mm} = 24 \mu\text{m}$$

Let's say that the transmitted position value is 123.

Thus the linear position value will be as follows:

Linear position value = transmitted position * linear resolution

$$\text{Linear position value} = 123 * 0.024 = 2.952 \text{ mm} = 2952 \mu\text{m}$$



EXAMPLE 2

Let's suppose that we are using the SFA-10000-GA-4000-... draw-wire encoder and the transmitted position value is 1569.

The encoder resolution is 4000 CPR. The linear resolution (0.05 mm) can be read in the product datasheet; anyway it can be easily calculated as follows:

$$\text{Linear resolution} = \frac{200}{4000} = 0.05 \text{ mm} = 50 \mu\text{m}$$

Thus the linear position value will be as follows:

Linear position value = $1569 * 0.05 = 78.45 \text{ mm} = 78450 \mu\text{m}$

5.3 Recommended transmission rates

The SSI interface has a frequency of data transmission ranging between 100 kHz and 2 MHz.

The CLOCK signals and the DATA signals comply with the "EIA standard RS-422". The clock frequency (baud rate) depends on the length of the cable and must comply with the technical information reported in the following table:

Cable length	Baud rate
< 50 m	< 400 kHz
< 100 m	< 300 kHz
< 200 m	< 200 kHz
< 400 m	< 100 kHz

The time interval between two Clock sequence transmissions must be at least 12 μs ($T_p = \text{pause time} > 12 \mu\text{s}$).

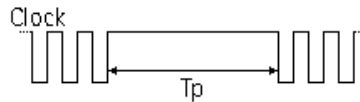

5.4 Max. speed and counting frequency

To convert the speed value from m/s into rpm (revolutions per minute), then you must use the following formula:

$$\text{Speed in rpm} = \frac{60 * \text{speed m/s}}{0.2}$$

If you need to convert the speed value from rpm into m/s, use the following formula instead:

$$\text{Speed in m/s} = \left(\frac{\text{rpm} * 200}{60} \right) / 1000$$



EXAMPLE

Let's assume that we are using the SFA-5000-BA-8192-... draw-wire encoder and the maximum speed of the application is 1 m/s. To calculate the counting frequency we must convert the speed expressed in m/s into rpm first.

Using the above formula you will get:

$$\text{Speed in rpm} = \frac{60 * 1}{0.2} = 300 \text{ rpm}$$

Please note that the maximum counting frequency of an encoder, expressed in kHz, results from the number of revolutions per minute (rpm) -i.e. its rotational speed- and the number of pulses per revolution (PPR) -i.e. its resolution. It can be calculated by using the following formula:

$$\text{Maximum counting frequency (kHz)} = \frac{\text{rpm} * \text{CPR}}{60 * 1000}$$

It follows that the higher the maximum rotational speed of the encoder and its resolution, the higher the counting frequency. This has to be considered carefully when you program the encoder, in particular referring to the maximum counting frequency of the encoder as stated in the technical specifications, to the following electronic equipment and to the length of the cables.

If you reverse the formula you can easily calculate the maximum number of revolutions starting from the value of the counting frequency (as allowed by the encoder, permitted by the subsequent electronics and accepted by the cable run) and the desired number of pulses per revolution:

$$\text{rpm} = \frac{\text{Maximum counting frequency (kHz)} * 60 * 1000}{\text{CPR}}$$

The reversed formula can be very useful -for instance- when you know the maximum counting frequency that is applicable to the system (because of the encoder, the following electronics and the cable length) and you need to calculate the maximum rotational speed the encoder is allowed to reach at the desired resolution.

5.5 Recommended SSI circuit

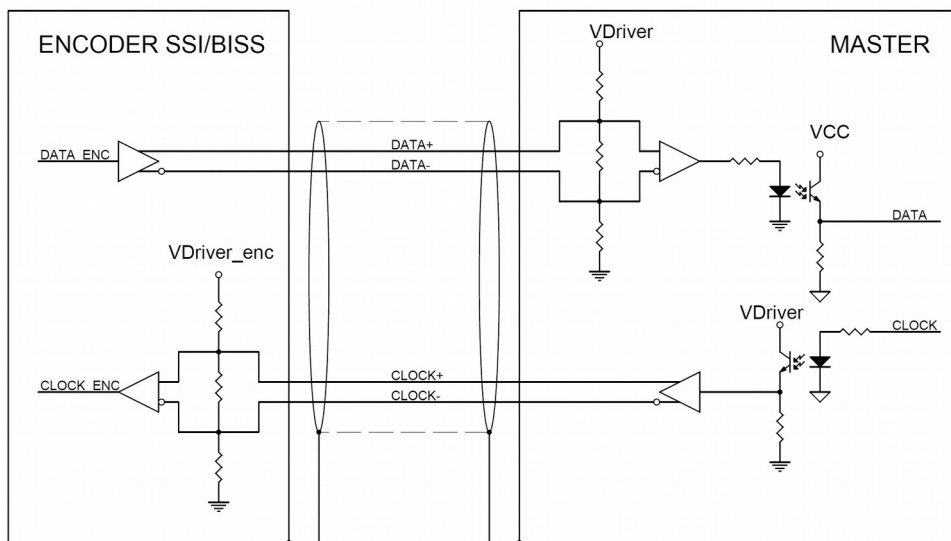

This page intentionally left blank

This page intentionally left blank

This page intentionally left blank



Document release	Description
1.0	1 st issue



Dispose separately



LIKA Electronic
Via S. Lorenzo, 25
36010 Carrè (VI) • Italy
Tel. +39 0445 806600
Fax +39 0445 806699

Italy: eMail info@lika.it - www.lika.it
World: eMail info@lika.biz - www.lika.biz