

Hall Effect Gear Tooth Sensors CYGTS101DC

CYGTS101DC Hall Effect Gear Tooth Sensor uses a magnetically biased Hall Effect integrated circuit to accurately sense movement of ferrous metal targets. This specially designed gear tooth sensor IC with bias magnet and discrete capacitor is sealed in plastic for physical protection and cost effective installation. The GTS IC works according to peak magnetic field detection. This Unit functions under power supply from 4.5 to 24VDC. Output is digital, current sinking (open collector, NPN). Reverse polarity protection is standard. The sensor will not be damaged if power is inadvertently wired backwards.

Features

- Sensing ferrous metal targets
- Digital current sinking output NPN (open collector)
- Good signal-to-noise ratio
- Excellent low speed performance
- Output amplitude not dependent on RPM
- Fast operating speed, over 15kHz
- EMI resistant
- Reverse polarity protection and transient protection
- Wide operating temperature $-40^{\circ}\text{C} \sim +135^{\circ}\text{C}$.

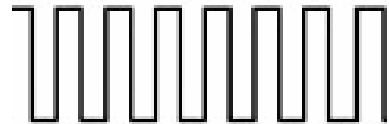
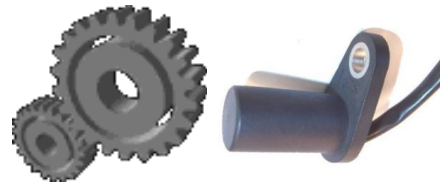

Applications

Automotive and Heavy Duty Vehicles:

- Camshaft and crankshaft speed and position
- Transmission speed
- Tachometers
- Anti-skid/traction control

Industrial Areas:

- Sprocket speed
- Chain link conveyor speed/distance
- Stop motion detector
- High speed and low cost proximity
- Tachometers, counters.

Absolute Maximum Ratings

Supply Voltage	-30V~+30V
Output Voltage	-0.5V~+30V
Output Current	Sinking 40mA
Operating Temperature Range	$-40^{\circ}\text{C} \sim +135^{\circ}\text{C}$

Order Guide

Part number	CYGTS101DC
Supply Voltage	4.5V ~ 24V
Output Saturation Voltage	0.4V (Sinking 20mA)
Sense Distance (gap)	0.2mm ~ 4.0mm (using reference target wheels)
RPM	10-8000
Switching time	Rise time: 10 μsec . max, fall time: 2 μsec . max.
Cross Reference	1GT101DC, 1GT103DC, 1GT105DC

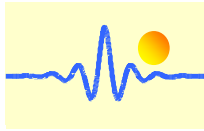

Reference Target Wheels and Sensing Gap (unit: mm)

Target wheel	Outer diameter	Tooth Height	Tooth Width	Tooth Spacing	Target Thickness	Teeth Number	Sensing Gap/distance
Target wheel 1	28	5.0	7.34	7.34	8.0	6	0.2-4.0
Target wheel 2	28	5.0	3.66	3.67	8.0	12	0.2-2.5
Target wheel 3	28	3.0	2.0	2.0	8.0	22	0.2-1.0
Target wheel 4	81.5	3.0	2.0	2.0	8.0	64	0.2-1.0

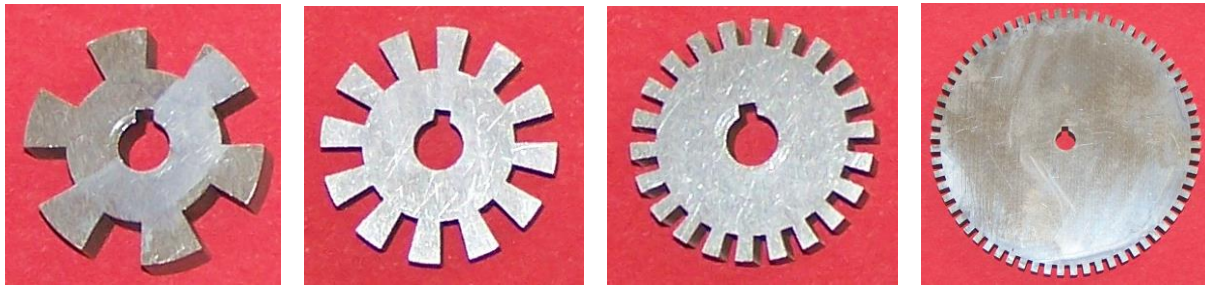

Characteristics will vary due to target size, geometry, location, and material. Optimum sensor performance is dependent on the following variables which must be considered in combination:

- Target material, geometry, and speed
- Gap between sensor and target
- Ambient temperature
- Magnetic material in close proximity.

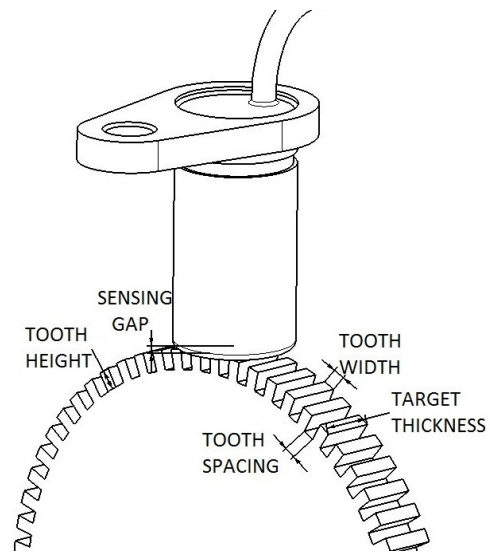
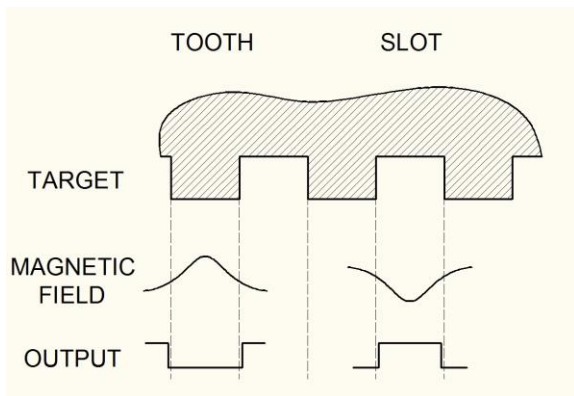

Application Notes

The output of these sensors is sinking current NPN (open collector). A pull-up resistor ($1k\Omega \sim 10k\Omega$) should be connected to the sensor output circuit (between power supply and output).

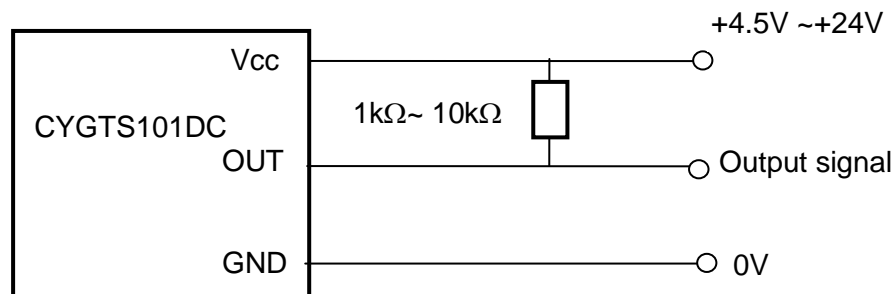

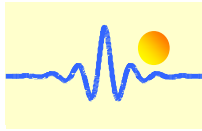

Mounting Dimensions (for reference only)

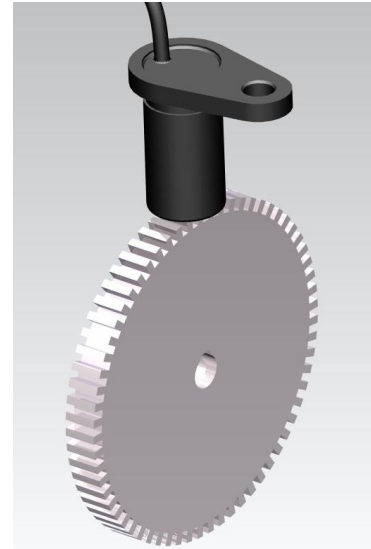

The standard length of the leads is 150mm; section: 4.7x2.3mm

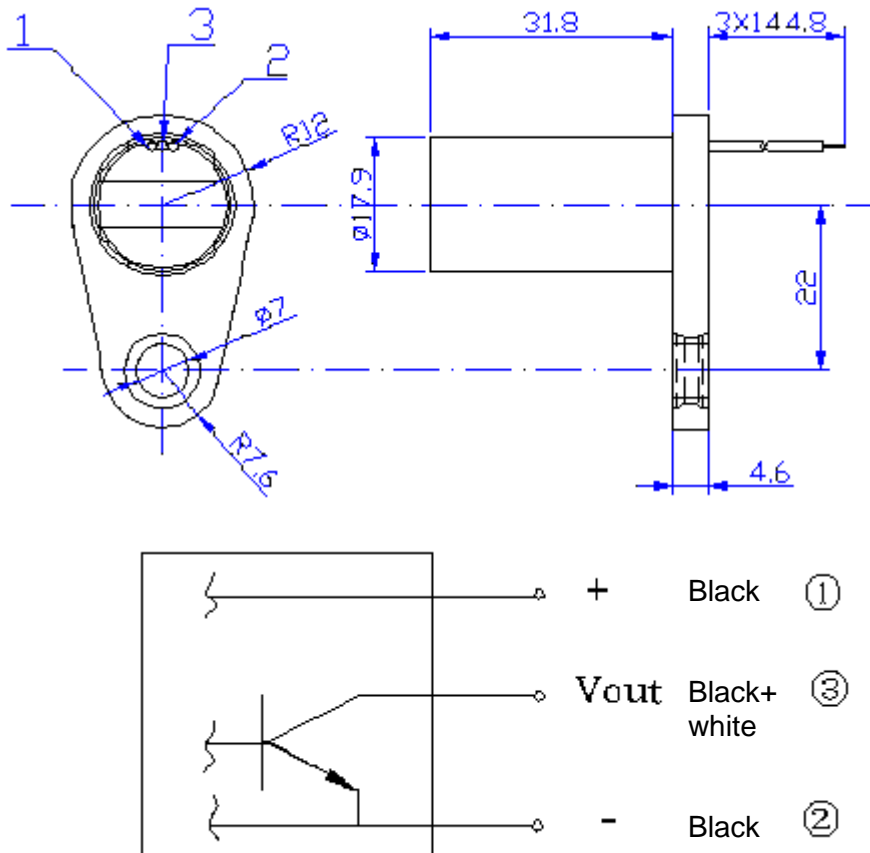

000 Евросенсор