

MJS-CS Flexible Coupling - Jaw - type (Short) - Clamping Type

WEB Selection Tool WEB CAD Download High torque Vibration absorption Electrical Insulation

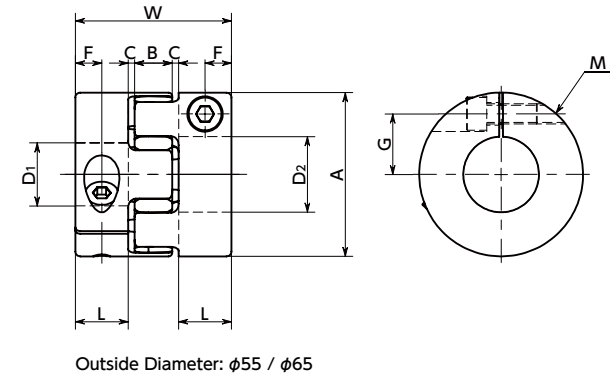
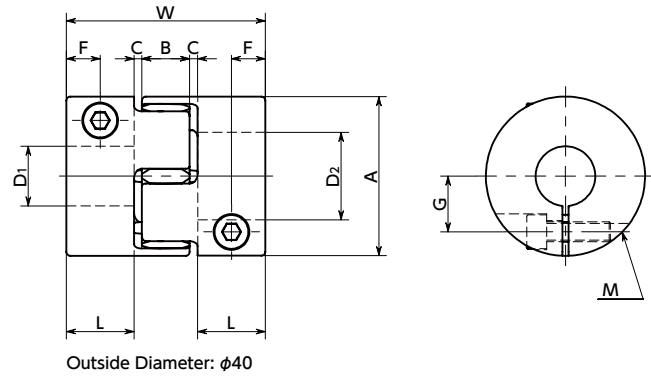

Dimensions

Unit : mm

Part Number	Bore Diameter	A	L	W	B	C*1	Sleeve E	F	G	M	Screw Tightening Torque (N·m)
MJS-40CS	8 - 20	40	17	50	12	2	18	8.5	14	M5	8
	22 - 25										
MJS-55CS	10 - 28	55	18	54	14	2	27.5	9	20	M6	13
	30 - 32										
MJS-65CS	14 - 32	65	21	62	15	2.5	31	10.5	24	M8	28
	35 - 38										

*1 : Use with C Dimension

Part Number	Standard Bore Diameter D1 · D2																			
	8	9.525	10	11	12	14	15	16	18	19	20	22	24	25	28	30	32	35	38	
MJS-40CS	●	●	●	●	●	●	●	●	●	●	●	●	●	●	●	●	●	●	●	●
MJS-55CS			●	●	●	●	●	●	●	●	●	●	●	●	●	●	●	●	●	●
MJS-65CS						●	●	●	●	●	●	●	●	●	●	●	●	●	●	●

- All products are provided with hex socket head cap screw.
- Recommended dimensional allowances of applicable shaft diameter are h6 and h7.
- A set of hubs with clamping type for one side and clamping + key type for the other side is available upon request.
- In case of mounting on D-cut shaft, be careful about the position of the D-cut surface of the shaft. → P.258

● Sleeve Details

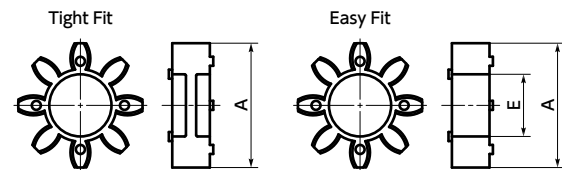

Performance

Part Number	Sleeve		Max. Bore Diameter (mm)	Rated ¹ torque (N·m)	Max. ¹ torque (N·m)	Zero Backlash ³ Allowable Transmission Torque (N·m)	Max. Rotational Frequency (min ⁻¹)	Moment ² of Inertia (kg·m ²)	Static Torsional Stiffness (N·m / rad)	Max. Lateral Misalignment (mm)	Max. Angular Misalignment (°)	Max. Axial Misalignment (mm)	Mass ² (g)	Sleeve Hardness (JIS)
	Tight Fit	Easy Fit												
MJS-40CS	BL	EBL	25	4.9	9.8	1.2	15000	2.7 x 10 ⁻⁵	380	0.15	1	+1.2 0	100	
MJS-55CS	BL	EBL	32	17	34		11000	1.1 x 10 ⁻⁴	1400	0.2	1	+1.4 0	210	A80
MJS-65CS	BL	EBL	38	46	92		9000	2.4 x 10 ⁻⁴	2800	0.2	1	+1.5 0	340	
MJS-40CS	WH	EW	25	10	20	1.2	15000	2.7 x 10 ⁻⁵	570	0.1	1	+1.2 0	100	
MJS-55CS	WH	EW	32	35	70		11000	1.1 x 10 ⁻⁴	1600	0.15	1	+1.4 0	210	A92
MJS-65CS	WH	EW	38	95	190		9000	2.4 x 10 ⁻⁴	3000	0.15	1	+1.5 0	340	
MJS-40CS	RD	ERD	25	17	34	1.2	15000	2.7 x 10 ⁻⁵	1200	0.1	1	+1.2 0	100	
MJS-55CS	RD	ERD	32	60	120		11000	1.1 x 10 ⁻⁴	2600	0.1	1	+1.4 0	210	A98
MJS-65CS	RD	ERD	38	160	320		9000	2.4 x 10 ⁻⁴	4900	0.1	1	+1.5 0	340	
MJS-40CS	GR	EGR	25	21	42	1.2	15000	2.7 x 10 ⁻⁵	3000	0.08	1	+1.2 0	100	
MJS-55CS	GR	EGR	32	75	150		11000	1.1 x 10 ⁻⁴	9000	0.08	1	+1.4 0	210	D64
MJS-65CS	GR	EGR	38	200	400		9000	2.4 x 10 ⁻⁴	13000	0.08	1	+1.5 0	340	

*1 : Correction of rated torque and max. torque due to load fluctuation is not required. However, if ambient temperature exceeds 30°C, be sure to correct the rated torque and max. torque with temperature correction factor shown in the table. **MJS-CS**'s allowable operating temperature is -20°C to 60°C.

*2 : These are values with max. bore diameter.

*3 : For transmission with Zero Backlash, please use a tight fit sleeve.

● Ambient Temperature / Temperature Correction Factor

Ambient Temperature	Temperature Correction Factor
-20°C to 30°C	1.00
30°C to 40°C	0.80
40°C to 60°C	0.70

● Part number specification

MJS-55CS-EGR-14-16

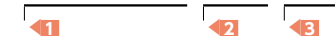

Additional Keyway at Shaft Hole → P.803 Available / Add'l charge
 Cleanroom Wash & Packaging → P.807 Available / Add'l charge
 Change to Stainless Steel Screw → P.805 Available / Add'l charge

MJS-CSK Flexible Coupling - Jaw - type (Short) - Clamping + Key Type

WEB Selection Tool WEB CAD Download High torque Vibration absorption Electrical Insulation

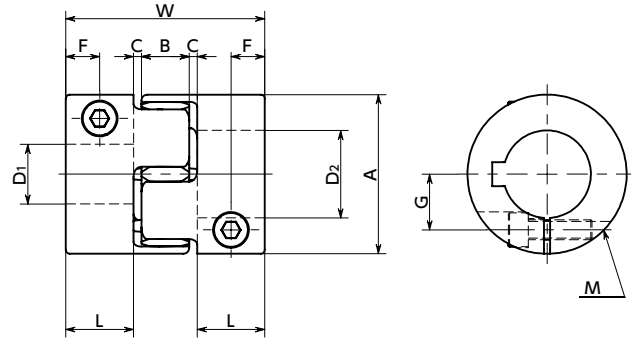

Outside Diameter: $\phi 40$

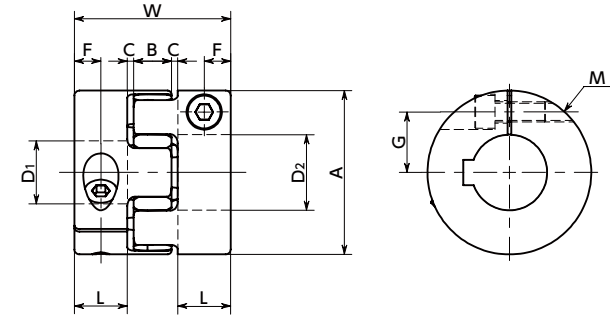

Outside Diameter: $\phi 55 / \phi 65$

Dimensions

Unit : mm

Part Number	Bore Diameter	A	L	W	B	C*1	Sleeve E	F	G	M	Screw Tightening Torque (N·m)
MJS-40CSK	10 - 20	40	17	50	12	2	18	8.5	14	M5	8
	22 - 25										15.75
MJS-55CSK	10 - 28	55	18	54	14	2	27.5	9	20	M6	13
	30 - 32										21
MJS-65CSK	14 - 32	65	21	62	15	2.5	31	10.5	24	M8	28
	35 - 38										25

*1 : Use with C Dimension

Part Number	Standard Bore Diameter $D_1 \cdot D_2$																
	10	11	12	14	15	16	18	19	20	22	24	25	28	30	32	35	38
MJS-40CSK	●	●	●	●	●	●	●	●	●	●	●	●	●	●	●	●	●
MJS-55CSK	●	●	●	●	●	●	●	●	●	●	●	●	●	●	●	●	●
MJS-65CSK	●	●	●	●	●	●	●	●	●	●	●	●	●	●	●	●	●

- All products are provided with hex socket head cap screw.
- Recommended dimensional allowances of applicable shaft diameter are h6 and h7.
- A set of hubs with clamping + key type for one side and clamping type for the other side is available upon request.
- In case of mounting on D-cut shaft, be careful about the position of the D-cut surface of the shaft. → P.258

● Sleeve Details

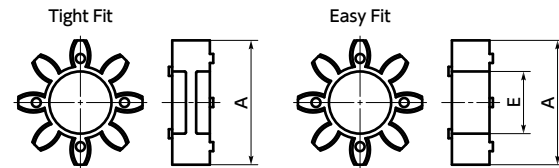

● Details of Shaft Hole

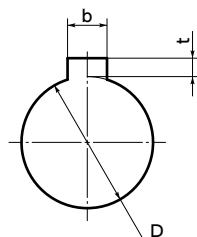

Standard Bore Diameter D	Keyway				Key Nominal Dimension b x h
	b		t		
	Standard Dimension	Allowance (JS9)	Standard Dimension	Allowance	
10 · 11 · 12	4	±0.0150	1.8	+0.1 0	4×4
14 · 15 · 16	5	±0.0150	2.3	+0.1 0	5×5
18 · 19 · 20 · 22	6	±0.0150	2.8	+0.1 0	6×6
24 · 25 · 28 · 30	8	±0.0180	3.3	+0.2 0	8×7
32 · 35 · 38	10	±0.0180	3.3	+0.2 0	10×8

Unit : mm

Additional Keyway at Shaft Hole → P.803 Cleanroom Wash & Packaging → P.807 Change to Stainless Steel Screw → P.805
Please feel free to contact us Available / Add'l charge Available / Add'l charge

Performance

Part Number	Sleeve		Max. Bore Diameter (mm)	Rated*1 torque (N·m)	Max.*1 torque (N·m)	Zero Backlash*3 Allowable Transmission Torque (N·m)	Max. Rotational Frequency (min ⁻¹)	Moment*2 of Inertia (kg·m ²)	Static Torsional Stiffness (N·m / rad)	Max. Lateral Misalignment (mm)	Max. Angular Misalignment (°)	Max. Axial Misalignment (mm)	Mass*2 (g)	Sleeve Hardness (JIS)
	Tight Fit	Easy Fit												
MJS-40CSK	BL	EBL	25	4.9	9.8	1.2	15000	2.7 x 10 ⁻⁵	380	0.15	1	+1.2 0	96	
MJS-55CSK	BL	EBL	32	17	34		11000	1.0 x 10 ⁻⁴	1400	0.2	1	+1.4 0	210	A80
MJS-65CSK	BL	EBL	38	46	92		9000	2.3 x 10 ⁻⁴	2800	0.2	1	+1.5 0	330	
MJS-40CSK	WH	EWH	25	10	20	1.2	15000	2.7 x 10 ⁻⁵	570	0.1	1	+1.2 0	96	
MJS-55CSK	WH	EWH	32	35	70		11000	1.0 x 10 ⁻⁴	1600	0.15	1	+1.4 0	210	A92
MJS-65CSK	WH	EWH	38	95	190		9000	2.3 x 10 ⁻⁴	3000	0.15	1	+1.5 0	330	
MJS-40CSK	RD	ERD	25	17	34	1.2	15000	2.7 x 10 ⁻⁵	1200	0.1	1	+1.2 0	96	
MJS-55CSK	RD	ERD	32	60	120		11000	1.0 x 10 ⁻⁴	2600	0.1	1	+1.4 0	210	A98
MJS-65CSK	RD	ERD	38	160	320		9000	2.3 x 10 ⁻⁴	4900	0.1	1	+1.5 0	330	
MJS-40CSK	GR	EGR	25	21	42	1.2	15000	2.7 x 10 ⁻⁵	3000	0.08	1	+1.2 0	96	
MJS-55CSK	GR	EGR	32	75	150		11000	1.0 x 10 ⁻⁴	9000	0.08	1	+1.4 0	210	D64
MJS-65CSK	GR	EGR	38	200	400		9000	2.3 x 10 ⁻⁴	13000	0.08	1	+1.5 0	330	

- *1 : Correction of rated torque and max. torque due to load fluctuation is not required. However, if ambient temperature exceeds 30°C, be sure to correct the rated torque and max. torque with temperature correction factor shown in the table. **MJS-CSK**'s allowable operating temperature is -20°C to 60°C.
- *2 : These are values with max. bore diameter.
- *3 : For transmission with Zero Backlash, please use a tight fit sleeve.

● Ambient Temperature / Temperature Correction Factor

Ambient Temperature	Temperature Correction Factor
-20°C to 30°C	1.00
30°C to 40°C	0.80
40°C to 60°C	0.70

● Part number specification

MJS-40CSK-EBL-14-16

