

# User's guide

## Hx58xSCx-... BiSS C-mode + Sin/Cos

### Sections

- 1 - Safety summary
- 2 - Identification
- 3 - Mounting instructions
- 4 - Electrical connections
- 5 - BiSS C-mode interface
- 6 - 1Vpp sine/cosine output signals
- 7 - Default parameters list

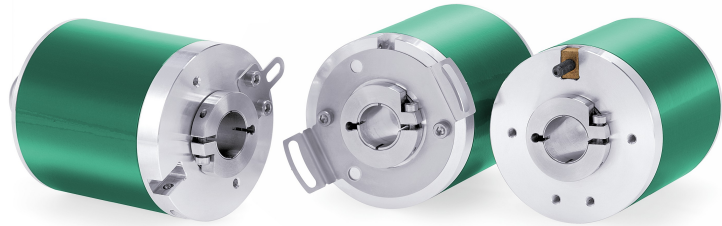

**BiSS**  
INTERFACE



### 1 - Safety summary



#### 1.1 Safety

- Always adhere to the professional safety and accident prevention regulations applicable to your country during device installation and operation;
- installation and maintenance operations have to be carried out by qualified personnel only, with power supply disconnected and stationary mechanical parts;
- device must be used only for the purpose appropriate to its design: use for purposes other than those for which it has been designed could result in serious personal and/or the environment damage;
- high current, voltage and moving mechanical parts can cause serious or fatal injury;
- warning! Do not use in explosive or flammable areas;
- failure to comply with these precautions or with specific warnings elsewhere in this manual violates safety standards of design, manufacture, and intended use of the equipment;
- Lika Electronic assumes no liability for the customer's failure to comply with these requirements.



#### 1.2 Electrical safety

- Turn off power supply before connecting the device;
- connect according to explanation in the "4 - Electrical connections" section on page 9;
- if not used, connect Preset / Offset and Counting direction inputs to 0Vdc;
  - to set the Preset / Offset, connect Preset / Offset input to +Vdc for 100  $\mu$ s at least, then disconnect +Vdc; normally voltage must be at 0Vdc; zero must be

set after Counting direction; we suggest setting the zero when the encoder shaft is not running;

- Counting direction: CW increasing count (viewed from fixing plate side): connect to 0Vdc; CCW increasing count: connect to +Vdc;
- in compliance with the 2014/30/EU norm on electromagnetic compatibility, following precautions must be taken:
  - before handling and installing, discharge electrical charge from your body and tools which may come in touch with the device;
  - power supply must be stabilized without noise, install EMC filters on device power supply if needed;
  - always use shielded cables (twisted pair cables whenever possible);
  - avoid cables runs longer than necessary;
  - avoid running the signal cable near high voltage power cables;
  - mount the device as far as possible from any capacitive or inductive noise source, shield the device from noise source if needed;
  - to guarantee a correct working of the device, avoid using strong magnets on or near by the unit;
  - minimize noise by connecting the shield and/or the connector housing and/or the frame to ground. Make sure that ground is not affected by noise. The connection point to ground can be situated both on the device side and on user's side. The best solution to minimize the interference must be carried out by the user.



### 1.3 Mechanical safety

- Install the device following strictly the information in the "3 - Mounting instructions" section on page 4;
- mechanical installation has to be carried out with stationary mechanical parts;
- do not disassemble the encoder;
- do not tool the encoder or its shaft;
- delicate electronic equipment: handle with care; do not subject the device and the shaft to knocks or shocks;
- respect the environmental characteristics declared by manufacturer;
- unit with solid shaft: in order to guarantee the maximum reliability over time of the mechanical parts, we recommend a flexible coupling to be installed to connect the encoder and the installation shaft; make sure the misalignment tolerances of the flexible coupling are respected;
- unit with hollow shaft: the encoder can be mounted directly on a shaft whose diameter has to respect the technical characteristics specified in the purchase order and clamped by means of the collar and the fixing plate into which an anti-rotation pin has to be inserted.

## 2 - Identification

Device can be identified through the **order code** and the **serial number** printed on the label applied to its body. Information is listed in the delivery document too. Please always quote the order code and the serial number when reaching Lika Electronic for purchasing spare parts or needing assistance. For any information on the technical characteristics of the product refer to the technical catalog.



**Warning:** encoders having order code ending with "/Sxxx" may have mechanical and electrical characteristics different from standard and be supplied with additional documentation for special connections (Technical info).

### 3 - Mounting instructions



**WARNING**

Installation and maintenance operations must be carried out by qualified personnel only, with power supply disconnected and mechanical parts absolutely in stop.

For any information on the mechanical data and the electrical characteristics of the encoder please refer to the technical catalog.

#### 3.1 Solid shaft encoders HS58, HS58S, HM58, HM58S

- Mount the flexible coupling **1** on the encoder shaft;
- fix the encoder to the flange **2** (or to the mounting bell) by means of screws **3**;
- secure the flange **2** to the support (or the mounting bell to the motor);
- mount the flexible coupling **1** on the motor shaft;
- make sure the misalignment tolerances of the flexible coupling **1** are respected.

##### 3.1.1 Customary installation

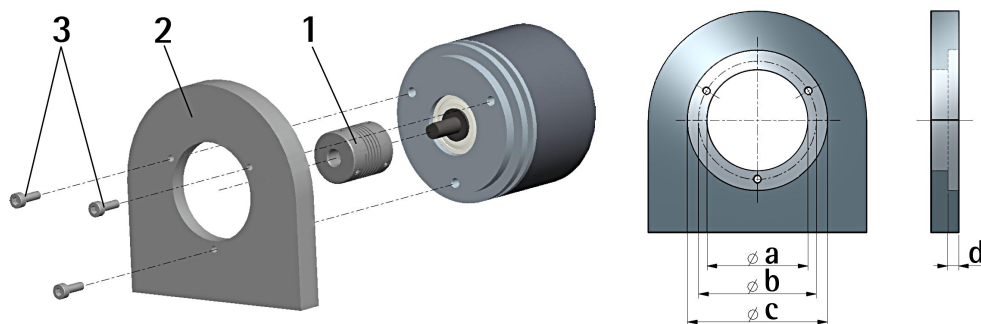

	a [mm]	b [mm]	c [mm]	d [mm]
HS58, HM58	-	42	50 F7	4
HS58S, HM58S	36 H7	48	-	-

3.1.2 Installation using fixing clamps (code LKM-386)

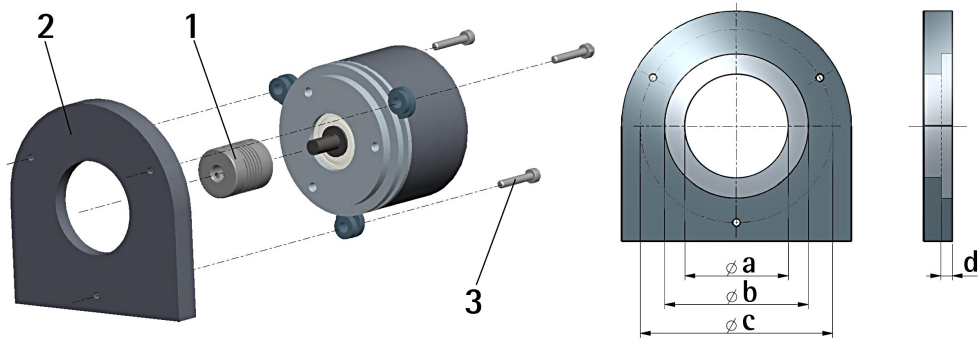

	a [mm]	b [mm]	c [mm]	d [mm]
HS58, HM58	-	50 F7	67	4
HS58S, HM58S	36 H7	-	67	-

3.1.3 Installation using a mounting bell (code PF4256)

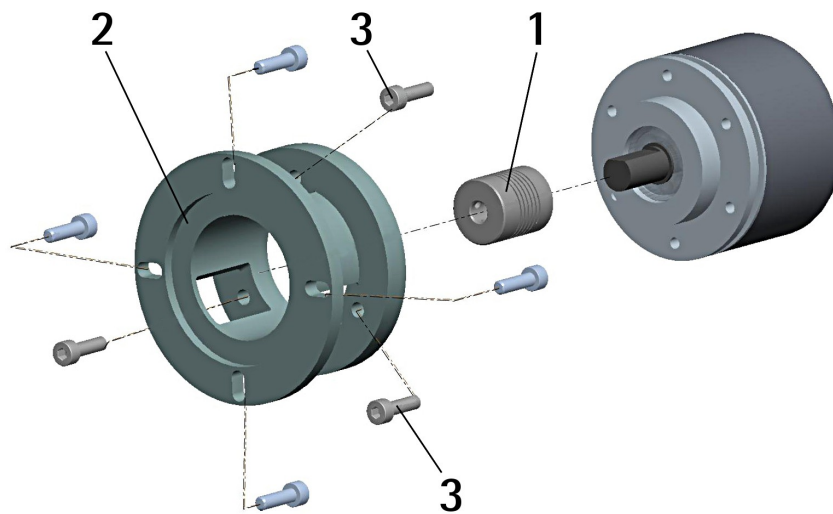

NOTE

In order to guarantee reliability over time of the encoder mechanical parts, we recommend a flexible coupling to be installed between the encoder and the motor shaft. Make sure the misalignment tolerances of the flexible coupling are respected.

## 3.2 Hollow shaft encoders

### 3.2.1 HSC58, HMC58

- Fasten the anti-rotation pin **1** to the rear of the motor (secure it using a locknut);
- mount the encoder on the motor shaft using the reducing sleeve **8** (if supplied). Avoid forcing the encoder shaft;
- insert the anti-rotation pin **1** into the slot on the flange of the encoder; this secures it in place by grub screw **2**, preset at Lika;
- fix the collar **3** to the encoder shaft (apply threadlocker to screw **3**).

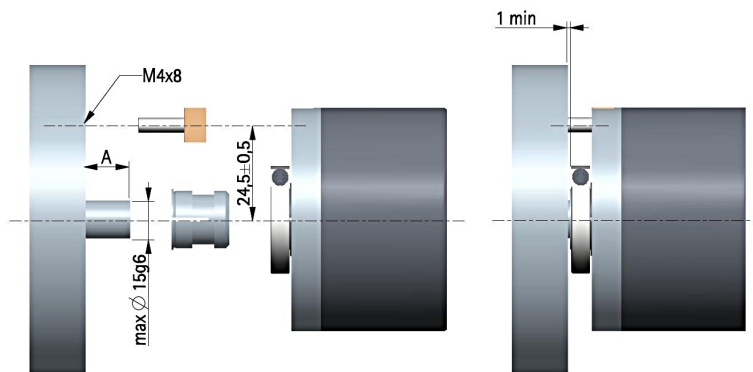
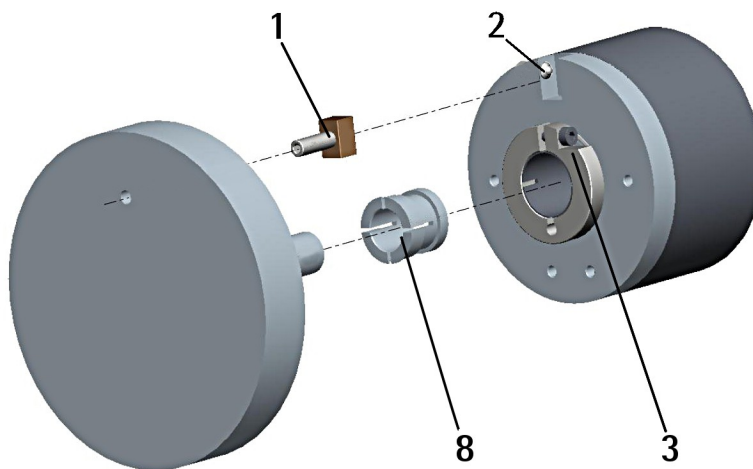

A = min. 8, max. 18 mm

3.2.2 HSC59, HMC59

- Mount the encoder on the motor shaft using the reducing sleeve **8** (if supplied). Avoid forcing the encoder shaft;
- fasten the fixing plate **4** to the rear of the motor using two M3 cylindrical head screws **5**;
- fix the collar **3** to the encoder shaft (apply threadlocker to screw **3**).

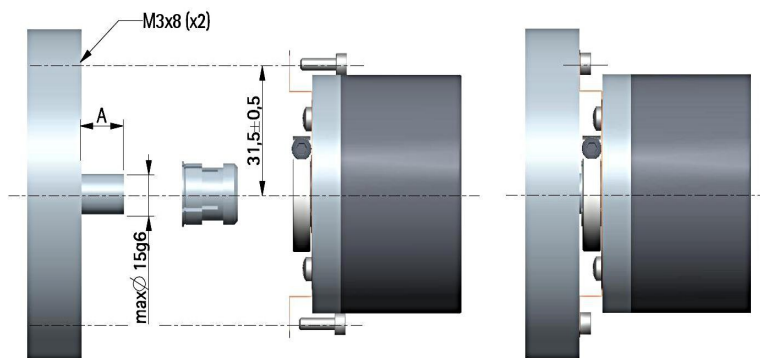
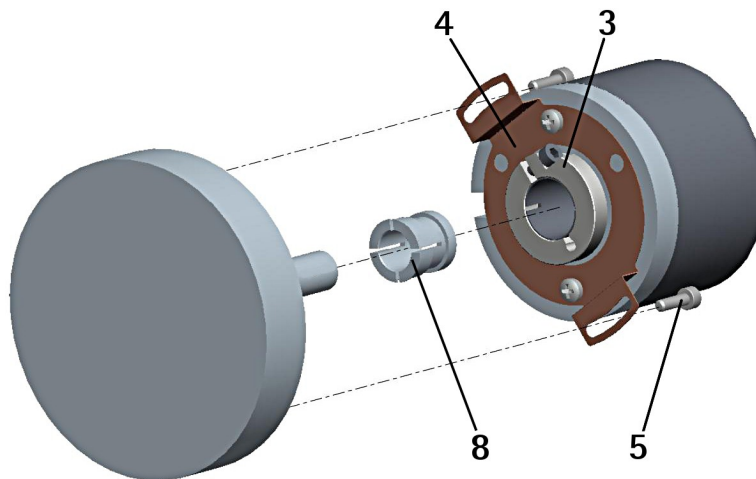

A = min. 8, max. 18 mm

3.2.3 HSC60, HMC60

- Fix the tempered pin **6** to the rear of the motor;
- mount the encoder on the motor shaft using the reducing sleeve **8** (if supplied). Avoid forcing the encoder shaft;
- make sure the anti-rotation pin **6** is inserted properly into the fixing plate **7**;
- fix the collar **3** to the encoder shaft (apply threadlocker to screw **3**).

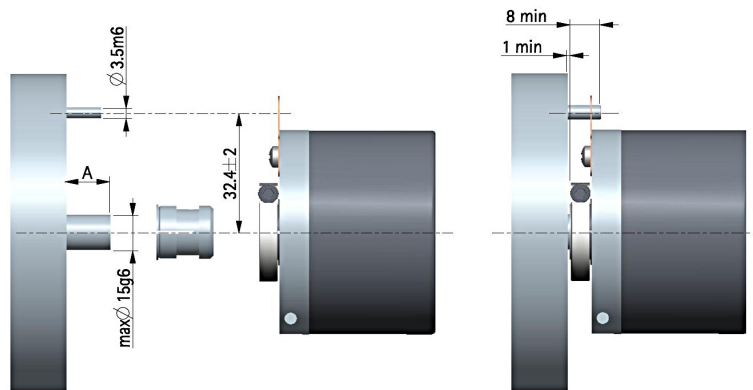
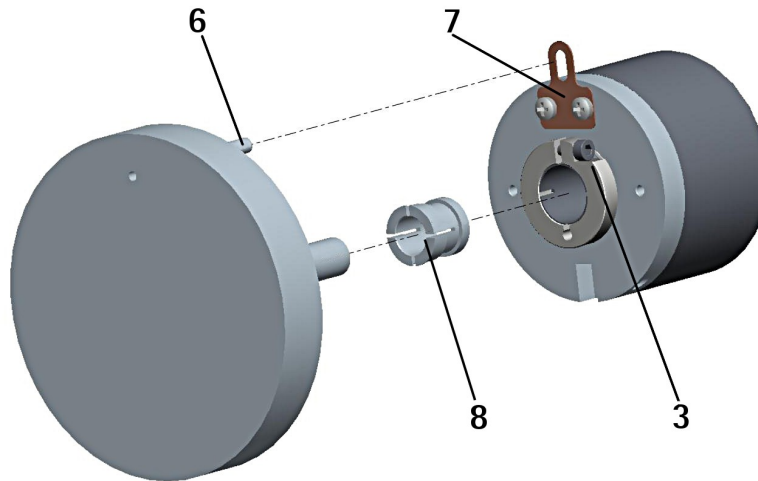

A = min. 8, max. 18 mm



**NOTE**

You are strongly advised not to carry out any mechanical operations (drilling, milling, etc.) on the encoder shaft. This could cause serious damages to the internal parts and an immediate warranty loss. Please contact our technical personnel for the complete availability of "custom made" shafts.



## 4 - Electrical connections



### WARNING

Power supply must be turned off before performing any electrical connection!



### WARNING

If wires of unused signals come in contact, irreparable damage could be caused to the device. Please insulate them singularly.

M23 12 pin	M12 12 pin	T12 cable	Function
1	4	Yellow	Clock IN - (MA -)
2	3	Violet	Clock IN + (MA +)
3	5	Grey	Data OUT + (SLO +)
4	6	Pink	Data OUT - (SLO -)
5	9	Green	A (Cos +)
6	10	Brown	/A (Cos -)
7	11	Red	B (Sin +)
8	8	Blue	Counting direction
9	7	White	Preset / Offset
10	12	Black	/B (Sin -)
11	2	Brown_Green	+Vdc <sup>1</sup>
12	1	White_Green	0Vdc
Case	Case	Shield	Shielding

1 See the order code for power supply voltage level



### EXAMPLE

HSx58x/SC1-... +Vdc = +5Vdc ± 5%

HSx58x/SC2-... +Vdc = +10Vdc +30Vdc

### 4.1 M23 12-pin connector

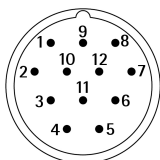

M23 12-pin connector  
Counter-clockwise  
Male frontal side

## 4.2 M12 12-pin connector

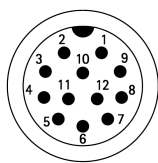

M12 12-pin connector  
Male frontal side

## 4.3 T12 cable specifications

Model: LIKA HI-FLEX twisted encoder cable type T12

Wires: 4 x 0.25 mm<sup>2</sup> + 4 x 2 x 0.14 mm<sup>2</sup> twisted pairs (24/26 AWG)

Jacket: Matt Polyurethane (TPU) halogen free, oil, hydrolysis, abrasion resistant

Shield: tinned copper braid, coverage  $\geq 85\%$

Outer diameter:  $\varnothing 6.1 \text{ mm} \pm 0.10 \text{ mm}$  (0.24"  $\pm$  0.0039")

Min. bend radius: fixed min. 25 mm / dynamic min. 45 mm

Work temperature: -40°C +90°C (-40°F +194°F) – dynamic installation / -50°C +90°C (-58°F +194°F) – fixed installation

Conductor resistance:  $\leq 90 \Omega/\text{km}$  (0.25 mm<sup>2</sup>) /  $\leq 148 \Omega/\text{km}$  (0.14 mm<sup>2</sup>)

## 4.4 GND connection

Minimize noise by connecting the shield and/or the connector housing and/or the frame to ground. Make sure that ground is not affected by noise. The connection point to ground can be situated both on the device side and on user's side. The best solution to minimize the interference must be carried out by the user.

## 4.5 1Vpp sinusoidal output signals

For any further information on the 1Vpp sinusoidal signals please refer to the "6 - 1Vpp sine/cosine output signals" section on page 27.

## 4.6 Counting direction input

The Counting direction input allows to set whether the position value output by the encoder increases when the encoder shaft rotates clockwise (CW) or counter-clockwise (CCW). The clockwise rotation is intended as shown in the Figure. If the Counting direction input is connected to 0Vdc, the position value increases when the encoder shaft rotates clockwise; on the contrary, if the Counting direction input is connected to +Vdc, the position value increases when the encoder shaft rotates counter-clockwise. If not used, connect the Counting direction input to 0Vdc (standard counting direction, see the Figure).

**WARNING**

The counting direction can be set also via BiSS interface. The parameter **Code sequence** in the **Configuration** register allows the operator to choose the options CW (clockwise direction) and CCW (counter-clockwise direction). When the counting direction is set to CW (default option) **-Code sequence = CW-**, if the Counting direction input has LOW logic level (0Vdc) the encoder will provide the increasing count when the encoder is turning clockwise (and the decreasing count when the encoder is turning counter-clockwise); on the contrary if the Counting direction input has HIGH logic level (+Vdc) the encoder will provide the increasing count when the encoder is turning counter-clockwise (and the decreasing count when the encoder is turning clockwise). When the option CCW is set **-Code sequence = CCW-**, if the Counting direction input has LOW logic level (0Vdc) the encoder will provide the increasing count when the encoder is turning counter-clockwise (and the decreasing count when the encoder is turning clockwise); on the contrary if the Counting direction input has HIGH logic level (+Vdc) the encoder will provide the increasing count when the encoder is turning clockwise (and the decreasing count when the encoder is turning counter-clockwise).

**WARNING**

After changing the counting direction you are required to set a new preset / offset.

**NOTE**

The counting direction function affects the absolute position information, not the sine/cosine signals.



#### 4.7 Preset / Offset input

Preset / Offset input is active only when the parameter **Enable preset / offset** in the **Configuration** register is enabled (see on page 19); otherwise the

hardware function is disabled. Furthermore it holds two different functions depending on the value of the parameter **Set preset / offset** in the **Configuration** register whether it is set to PRESET or OFFSET. In the first case (**Set preset / offset** = PRESET) the input is used to set the preset (**Preset / Offset** register, see on page 22); while in the second case (**Set preset / offset** = OFFSET) it is used to set the offset (**Preset / Offset** register, see on page 22).

The output information can be forced to a desired value (set next to the **Preset / Offset** register) through a command sent via the PRESET / OFFSET input by a PLC or a button. To set the preset / offset stop the encoder in the desired position and then connect Preset / Offset input to +Vdc for 100 µs at least.

After this, the position information output by the encoder in that point will be the one set (and then loaded to the encoder) next to the **Preset / Offset** register. By default the preset value is 0. Connect Preset input to 0Vdc if not used. To set the preset / offset, connect Preset / Offset input to +Vdc for 100 µs at least, then disconnect +Vdc. Normally voltage must be at 0Vdc; Preset / Offset must be set after Counting direction. We suggest performing the preset / offset setting when the encoder is in stop.

**WARNING**

Check the value in the **Preset / Offset** register and activate the function (either through the Preset / Offset input or by using the **Configuration** register) every time you change the value next to the **Counts per revolution** and/or **Number of revolutions** registers.

**NOTE**

The Preset / Offset can be activated also by using the **Set preset / offset** function of the **Configuration** register. For detailed information please refer to the **Preset / Offset** registers on page 22 and to the **Configuration** register on page 19.

## 5 - BiSS C-mode interface

Lika encoders are always Slave devices and comply with the "BiSS C-mode interface" and the "Standard encoder profile".

Refer to the official BiSS website for all information not listed in this manual ([www.biss-interface.com](http://www.biss-interface.com)).

The device is designed to work in a point-to-point configuration and must be installed in a "single Master, single Slave" network (not on a "single Master, multi Slave" network).

CLOCK IN (MA) and DATA OUT (SLO) signal levels are according to the "EIA standard RS-422".



### WARNING

Never install the encoder in a "single Master, multi Slave" network.

### 5.1 XML file

The product is supplied with an XML file **idbiss4C69.xml** (it can be downloaded from Lika's web site). Install the XML file on the BiSS Master device.

### 5.2 Communication

The BiSS C-mode protocol uses two types of data transmission protocols:

- **Single Cycle Data (SCD):** it is the main data transmission protocol. It is used to send process data from the Slave to the Master. For any information refer to the "5.3 Single Cycle Data" section on page 14.
- **Control Data (CD):** transmission of a single bit following the SCD data. It is used to read or write data into the registers of the Slave. For any information refer to the "5.4 Control Data CD" section on page 15.

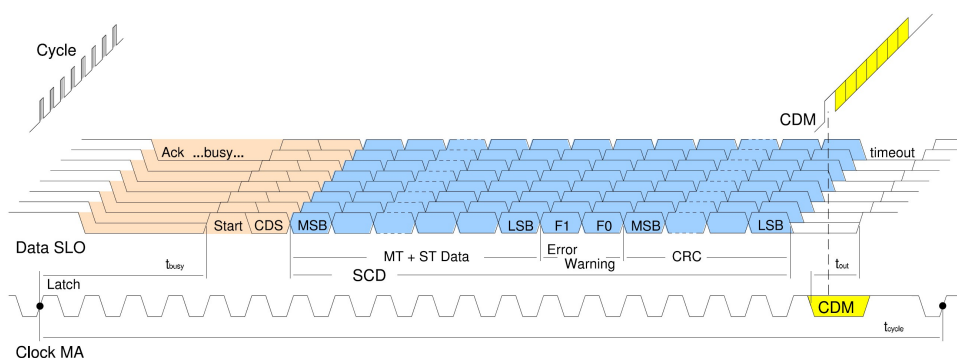

### 5.3 Single Cycle Data

Hsx58x and HM58x have different SCD structure.

#### 5.3.1 SCD structure for Hsx58x (singleturn encoder)

SCD (32 bits) consists of the following elements: position value (24 bits), 1 error bit (nE), 1 warning bit (nW) and CRC checking (6 bits).

bits	31 ... 8	7	6	5 ... 0
function	position	error	warning	CRC

#### Position (24 bits)

It is the process data transmitted from the Slave to the Master.

The transmission starts with msb (most significant bit) and ends with lsb (least significant bit).

bit	31 ... 26	25	...	8
value	000000	msb	...	lsb

#### Error (1 bit)

Not used (nE = "1")

#### Warning (1 bit)

Not used (nW = "1")

#### CRC (6 bits)

Correct transmission control (inverted output). Cyclic Redundancy Check is an error checking which is the result of a "Redundancy Check" calculation performed on the message contents. This is intended to check whether transmission has been performed properly. It is 6-bit long.

Polynomial:  $X^6+X^1+1$  (binary: 1000011)

#### Logic circuit:

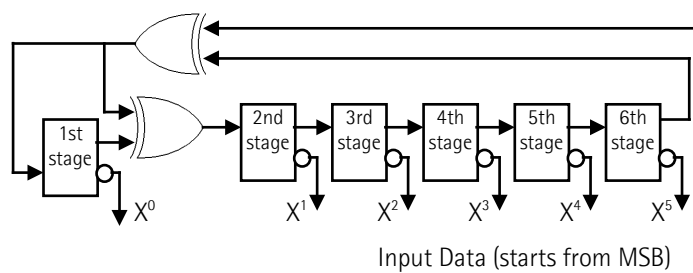

### 5.3.2 SCD structure for HMx58x (multiturn encoder)

SCD (38 bits) consists of the following elements: position value (32 bits) and CRC checking (6 bits).

<b>bits</b>	<b>37 ... 6</b>	<b>5 ... 0</b>
<b>function</b>	position	CRC

#### Position (32 bits)

It is the process data transmitted from the Slave to the Master.

The transmission starts with msb (most significant bit) and ends with lsb (least significant bit).

<b>bit</b>	<b>37</b>	<b>24</b>	<b>23</b>	<b>6</b>
<b>value</b>	msb	...	...	lsb
	multiturn position		singleturn position	

#### CRC (6 bits)

Correct transmission control (inverted output). Cyclic Redundancy Check is an error checking which is the result of a "Redundancy Check" calculation performed on the message contents. This is intended to check whether transmission has been performed properly. It is 6-bit long.

Polynomial:  $X^6+X^1+1$  (binary: 1000011)

#### Logic circuit:

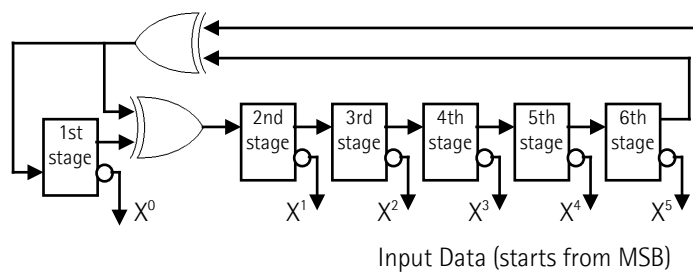

### 5.4 Control Data CD

Main control data is described in this section. Please refer to the official BiSS documents for complete CD structure: "BiSS C Protocol Description" in the [BiSS homepage](#).

#### Register address (7 bits)

It sets the number of the register you need either to read or to write. It is 7-bit long.

**RW (2 bits)**

**RW** = "01": when you need to write in the register.

**RW** = "10": when you need to read in the register.

It is 2-bit long.

**DATA (8 bit)**

When you need to write in a register (**DATA** = "01"), it allows to enter the value to be written in the register (transmitted from the Master to the Slave).

When you need to read in a register (**DATA** = "10"), it shows the value read in the register (transmitted from the Slave to the Master).

It is 8-bit long.

**Data bit structure:**

<b>bit</b>	<b>7</b>	...	...	<b>0</b>
	msb	...	...	lsb

**CRC (4 bits)**

Correct transmission control (inverted output). Cyclic Redundancy Check is an error checking which is the result of a "Redundancy Check" calculation performed on the message contents. This is intended to check whether transmission has been performed properly. It is 4-bit long.

Polynomial:  $X^4+X^1+1$  (binary: 10011)

**Logic circuit:**

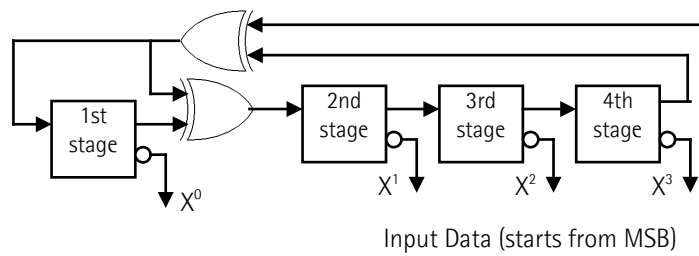



## 5.5 Used registers

Register (hex)	Function
42 and 43	Profile ID
44 ... 47	Serial number
48	Command
49	Configuration
4B ... 4D	Counts per revolution
4E and 4F	Number of revolutions
50 ... 53	Preset / Offset
55	Device type
56	N° of bits used for singleturn
57	N° of bits used for multiturn
58	SIN/COS resolution
78 ... 7D	Device ID
7E and 7F	Manufacturer ID

All registers described in this section are listed as follows:

### Function name

#### [Address, Attribute]

Description of the function and specification of the default value.

- Address: the register address is expressed in hexadecimal notation.
- Attribute:
  - ro = read only
  - rw = read and write
  - wo = write only
- Default parameter value is written in **bold**.

### Profile ID

#### [42 e 43, ro]

These registers contain the identification code of the used profile.

Register	42	43
HSx58x	28 hex	12 hex
HMx58x	00	00

See "Standard encoder profile", "data format", "Variant 0-24".

### Serial number

#### [44 ... 47, ro]

These registers contain the serial number of the device expressed in hexadecimal notation. They are intended to inform about the year of production, the week of production and the serial number in ascending order.

Register 44: year of production

Register 45: week of production

Registers 46 and 47: serial number in ascending order



Register	44	45	46	47
Hex	0A	E8	69	EE
Dec	18 30 03630			

18 = year of production (first two digits)

30 = week of production (third and fourth digit)

03630 = serial number in ascending order (remaining digits)

### Command

[48, wo]

Value	Function
00	Normal operation
01	Save parameters on EEPROM
02	Save and activate Preset / Offset
04	Load and save default parameters

After having set a new value in some register, use the **Save parameters on EEPROM** function in this register to store it. Set "01" in the register.

After having set a new value in some register, use the **Save and activate Preset / Offset** function in this register to both store it and activate the preset / offset function in the same time. Set "02" in the register.

As soon as the command is sent, the register is set back to "00" (**Normal operation**) automatically.

Wait min. 30 ms (EEPROM writing time) before using a new function.

**Load and save default parameters:** default parameters are set at the factory by Lika Electronic engineers to allow the operator to run the device for standard operation in a safe mode. As soon as the command is sent the default parameters are uploaded and activated. All parameters which have been set previously are overwritten, thus previously set values are lost. The complete list of machine data and relevant default parameters preset by Lika Electronic engineers is available on page 29. Set "04" in the register.

### WARNING

As soon as the command is sent, all parameters which have been set previously are overwritten, thus previously set values are lost!



## Configuration

[49, rw]

Bit	Function	Bit = 0	Bit = 1
0	Not used		
1	Set preset / offset	Preset	Offset
2	Enable preset / offset	Enable	Disable
3	Not used		
4	Not used		
5	Output code	Gray	Binary
6	Code sequence	CW	CCW
7	Not used		

### Set preset / offset

This parameter is available only if the parameter **Enable preset / offset** is set to ENABLE. It allows to activate either the preset function (**Set preset / offset** = PRESET) or the offset function (**Set preset / offset** = OFFSET); the Preset or Offset value has to be set in the **Preset / Offset** register. After having enabled the preset / offset functions (**Enable preset / offset** = ENABLE), this item allows to activate either the preset function or the offset function. The value set in the **Preset / Offset** register will have a different meaning depending on the value of this parameter whether it is set to PRESET or OFFSET. In the first case (**Set preset / offset** = PRESET) the **Preset / Offset** register is used to set the preset, i.e. any desired position value (less than then total resolution) can be set for the actual position of the encoder shaft (e.g. "0", zero setting); while in the second case (**Set preset / offset** = OFFSET) the **Preset / Offset** register is used to set the offset, i.e. the system adds an offset to the actual position: position = actual position + Offset. To activate the preset / offset value use the **Save and activate Preset / Offset** function in the **Command** register (set "02" in the register 48); or use the Preset / Offset input, see on page 11.

For any information on the preset and the offset functions refer to the register **Preset / Offset** on page 22.

### Enable preset / offset

It enables or disables the preset/offset function. After having enabled the use of the functions you have to choose whether to activate the preset or the offset in the **Set preset / offset** parameter. Then to activate a new value set it next to the **Preset / Offset** register and send the "**Save and activate Preset / Offset**" function (set "02" in the register 48 **Command**); or use the Preset / Offset input, see on page 11.

### Output code

It allows to select the code for the transmission of the position value: 0 = Gray code; 1 = Binary code.

### Code sequence

It allows to set whether the position information output by the encoder increases when the shaft rotates clockwise or counter-clockwise. Clockwise and counter-clockwise rotations are viewed from the shaft side. Please note that the counting direction affects the absolute position information, not the sine/cosine signals. It is possible to choose the following options: CW and CCW. When the counting direction is set to CW **-Code sequence = CW-**, if the Counting direction input (see on page 10) has LOW logic level (0Vdc) the encoder will provide the increasing count when the encoder is turning clockwise (and the decreasing count when the encoder is turning counter-clockwise); on the contrary if the Counting direction input has HIGH logic level (+Vdc) the encoder will provide the increasing count when the encoder is turning counter-clockwise (and the decreasing count when the encoder is turning clockwise). When the option CCW is set **-Code sequence = CCW-**, if the Counting direction input has LOW logic level (0Vdc) the encoder will provide the increasing count when the encoder is turning counter-clockwise (and the decreasing count when the encoder is turning clockwise); on the contrary if the Counting direction input has HIGH logic level (+Vdc) the encoder will provide the increasing count when the encoder is turning clockwise (and the decreasing count when the encoder is turning counter-clockwise). For any information on the Counting direction input refer to the "4.6 Counting direction input" section on page 10.

The new setting will be active immediately after transmission. Use the "**Save parameters on EEPROM**" function (set "01" in the register 48 **Command**) to store the new value.

Default = **20h**

### Counts per revolution

[4B ... 4D, rw]

These registers set the number of information per revolution (singleturn resolution). You are allowed to set whatever integer value less than or equal to the number of physical information per revolution. Anyway we suggest always setting a value which is a power of 2 in order to prevent the encoder from working within the limits of the so-called "red zone" thus causing a counting error. For any information on the "red zone" refer to the section "5.8 Red zone" on page 25.

The counts per revolution will be forced to the default value (number of physical information per revolution) if the entered value is out of the allowed range.

The new setting will be active immediately after transmission. Use the "**Save parameters on EEPROM**" function (set "01" in the register 48 **Command**) to store the new value.

Default = **262 144 (0004 0000 hex, 18 bits)** for HSx58x

Default = **65 536 (0001 0000 hex, 16 bits)** for HMx58x

After the modification of registers 4B ... 4D **Counts per revolution** Preset and Offset values have to be updated according to the new resolution!

### Number of revolutions

#### [4E and 4F, rw]

These registers set the number of revolutions (multiturn resolution).

Possible values are less than or equal to the number of physical revolutions. We suggest always setting a value which is a power of 2 (1, 2, 4, ...2048, 4096, ...) in order to prevent the encoder from working within the limits of the so-called "red zone" thus causing a counting error. For any information on the "red zone" refer to the section "5.8 Red zone" on page 25.

The number of revolutions will be forced to the default value (number of physical revolutions) if the entered value is out of the allowed range.

The new setting will be active immediately after transmission. Use the "**Save parameters on EEPROM**" function (set "01" in the register 48 **Command**) to store the new value.

Default = **1 (0001 hex)** for HSx58x

Default = **16 384 (0000 4000 hex, 14 bits)** for HMx58x

After the modification of registers 4E and 4F **Number of revolutions** Preset and Offset values have to be updated according to the new resolution!



#### EXAMPLE

"HS58**18**/SCx-...": singleturn encoder

"Hardware counts per revolution" = **18** bits/turn (262 144 cpr)

"Hardware number of turns" = 1

"Hardware total resolution" = 18 bits (262 144 \* 1 = 262 144)

"HM58**16/16384**-SCx-...": multiturn encoder

"Hardware counts per revolution" = **16** bits/turn (65 536 cpr)

"Hardware number of turns" = 14 bits (**16 384** turn)

"Hardware total resolution" = 30 bits (65 536 \* 16 384 = 1 073 741 824)

Let's suppose you need to set the following encoder: multiturn encoder  
"HM58**16/16384**SCx-..."

Its hardware resolution is as follows:

"Hardware counts per revolution" = 65 536 ( $2^{16}$ )

"Hardware number of turns" = 16 384 ( $2^{14}$ )

"Hardware total resolution" = 1 073 741 824 ( $2^{30}$ )

You need to set: 2048 steps per revolution \* 1024 turns:

"**Counts per revolution**" = 2048: registers 4B ... 4D = 00 08 00 hex

"**Number of revolutions**" = 1024: registers 4E and 4F = 04 00 hex

"Total resolution" = 2048 \* 1024 = 2 097 152.

## Preset / Offset

[50 ... 53, rw]

This function is available only if the parameter **Enable preset / offset** in the **Configuration** register is set to ENABLE. Furthermore it has a double function depending on whether the parameter **Set preset / offset** in the **Configuration** register is set to PRESET or OFFSET. In the first case (**Set preset / offset** = PRESET) the **Preset / Offset** register is used to set the preset; while in the second case (**Set preset / offset** = OFFSET) the **Preset / Offset** register is used to set the offset. Set the preset / offset value only when the device is not moving.

### Preset

The Preset function is meant to assign a value to a desired physical position of the encoder. The chosen physical position will get the value set next to this item and all the previous and following positions will get a value according to it. This function is useful, for example, when the zero position of the encoder and the zero position of the axis need to match. The preset value will be set for the position of the encoder in the moment when the preset value is activated. To activate the preset, stop the encoder in the desired position, enter the desired value next to this **Preset / Offset** register and then send the **Save and activate Preset / Offset** command in the **Command** register (set "02" in the register 48); otherwise connect the Preset / Offset input as explained on page 11.

### Offset

The offset function is meant to assign a value to a desired physical position of the encoder so that the output position information is shifted according to the value set next to this **Preset / Offset** register. In other words, it adds an offset to the actual position so that: position = actual position + Offset. The number of transmitted values will match the set resolution, but the output information will range between the **Preset / Offset** value (minimum value) and the sum of the set resolution + the **Preset / Offset** value (maximum value). The offset value will be set for the position of the encoder in the moment when the offset value is activated. To activate the offset, stop the encoder in the desired position, enter the desired value next to this **Preset / Offset** register and then send the **Save and activate Preset / Offset** command in the **Command** register (set "02" in the register 48); otherwise connect the Preset / Offset input as explained on page 11.

### Preset / Offset structure:

Reg.	50	51	52	53
	MSB	...	...	LSB
	$2^{31} - 2^{24}$	$2^{23} - 2^{16}$	$2^{15} - 2^8$	$2^7 - 2^0$

Use the "**Save and activate Preset / Offset**" function (set "02" in the register 48 **Command**) to store and activate the new value.

The Preset value must be less than the "Total resolution". The Offset value must be less than or equal to the difference between the hardware total resolution and the total resolution.

Default = 00h.

**Device type**
**[55, ro]**

It describes the type of device.

Default = **03h**: rotary singleturn encoder BiSS + Sin/Cos (HSx58xSCx-...)

Default = **04h**: rotary multiturn encoder BiSS + Sin/Cos (HMx58xSCx-...)

**N° of bits used for singleturn**
**[56, ro]**

This register contains the number of bits used for the singleturn resolution according to **Counts per revolution** (registers 4B ... 4D).

Default = **18h** for both HSx58x and HMx58x

**N° of bits used for multiturn**
**[57, ro]**

This register contains the number of bits used for the multiturn resolution according to **Number of revolutions** (registers 4E and 4F).

Default = **00h** for HSx58x

Default = **0Eh** for HMx58x

**SIN/COS resolution**
**[58, ro]**

This register shows the number of Sine/Cosine periods per revolution.

Default = **10h**: 2048 Sine/Cosine signals per revolution

**Device ID**
**[78 ... 7D, ro]**

These registers show the Device ID.

Singleturn encoder:

Reg.	78	79	7A	7B	7C	7D
Hex	48	53	49	37	xx	xx
ASCII	H	S	I	7	-	-

xx = software version

Multiturn encoder:

Reg.	78	79	7A	7B	7C	7D
Hex	48	4D	49	37	xx	xx
ASCII	H	M	I	7	-	-

xx = software version

Registers 78 and 79 show the series of the encoder (HS / HM).

Registers 7A and 7B show the interface (I7 = BiSS C-mode interface).

Registers 7C and 7D show the software version.

## Manufacturer ID

[7E and 7F, ro]

These registers contain the Manufacturer ID.

Reg.	7E	7F
Hex	4C	69
ASCII	L	i

Li = Lika Electronic.

## 5.6 Application note

Data transmission:

Parameter	Value
Clock Frequency	Min 200 KHz, max 10 MHz
BiSS Timeout	Self-adaptable to clock, max 10 $\mu$ s



## 5.7 Examples

All values are expressed in hexadecimal notation.

### 5.7.1 Setting the Configuration register:

We need to set preset, Binary output code, inverted code sequence.

Bit 0	= not used	= 0
Bit 1 <b>Set preset / offset</b>	= PRESET	= 0
Bit 2 <b>Enable preset / offset</b>	= ENABLE	= 0
Bit 3	= not used	= 0
Bit 4	= not used	= 0
Bit 5 <b>Output code</b>	= BINARY	= 1
Bit 8 <b>Code sequence</b>	= CCW	= 1
Bit 7	= non used	= 0

$01100000_2 = 60$  hex

Function	ADR	DATA Tx
writing the <b>Configuration</b> register	49	60
<b>Save parameters on EEPROM</b>	48	01

### 5.7.2 Setting the Preset / Offset:

After having activated the PRESET function (**Enable preset / offset** = ENABLE; **Set preset / offset** = PRESET in the **Configuration** register, see the previous section), you want to set the new Preset value =  $100000_{10} = 01\ 86\ A0h$



Function	ADR	DATA Tx
writing the <b>Preset / Offset</b> register	50	00
	51	01
	52	86
	53	A0
<b>Save and activate Preset / Offset</b>	48	02

### 5.8 Red zone

Most encoders suffer the problem of the so-called "red zone". This problem occurs when the overall resolution (i.e. number of information per revolution \* number of revolutions) is not a power of 2.

When this problem arises, the device must operate within the "red zone" limits for some positions. The size of the "red zone" is variable. To calculate it we must subtract the overall set resolution from the overall physical resolution of the device as many times as until the difference is less than the overall set resolution. When the encoder crosses the limit of the last value in the overall physical resolution, a counting error occurs, i.e. a jump in the position count. The problem is represented graphically in the following Figure.

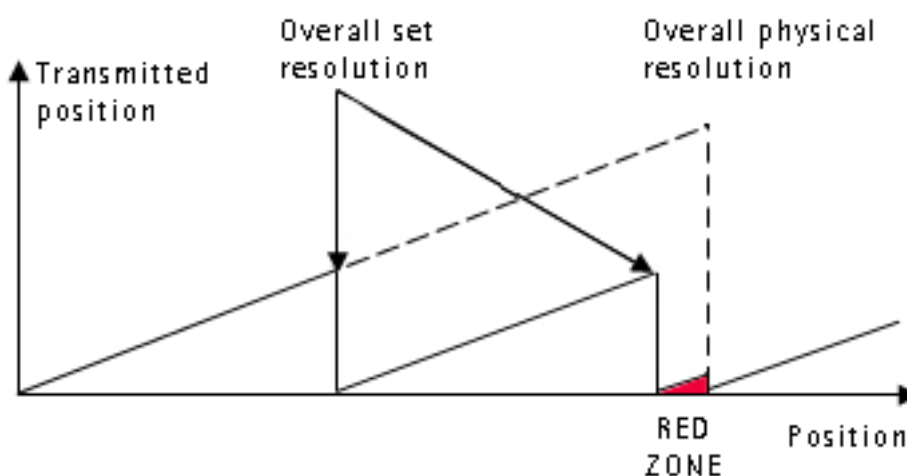

#### EXAMPLE

**Hx58x 16/16384** multiturn encoder

Physical resolution:

- Hardware Singleturn resolution = 65,536 counts/turn = 16 bits ( $2^{16}$ )
- Hardware Multiturn resolution = 16,384 revolutions = 14 bits ( $2^{14}$ )
- Overall physical resolution = 1 073 741 824 = 30 bits ( $2^{30}$ )

Set values:

- **Counts per revolution** = 65,536 =  $2^{16}$
- **Number of revolutions** = 6,748 = it is NOT a power of 2
- Overall set resolution = 442 236 928 = it is NOT a power of 2

This can be proved easily:

$$\frac{\text{Overall physical resolution}}{\text{Overall set resolution}} = \frac{1\,073\,741\,824}{442\,236\,928} = 2.427\dots$$

It follows that for 189 267 968 positions ( $1\,073\,741\,824 - 2 * 442\,236\,928 = 189\,267\,968$ ), i.e. for 2,888 revolutions, the encoder will work within the limits of the so-called "red zone". After position 189 267 967 (i.e. at the end of the "red zone") a position error (namely, a "jump" in the position count) will happen as the following position will be "0". See the Figure in the previous page.

Please pay the greatest attention using data transmitted by the encoder while running within the limits of the "red zone". When crossing the limit between "red zone" and normal running a position error occurs (i.e. a "jump" in the position count).

### 5.9 Recommended BiSS input circuit

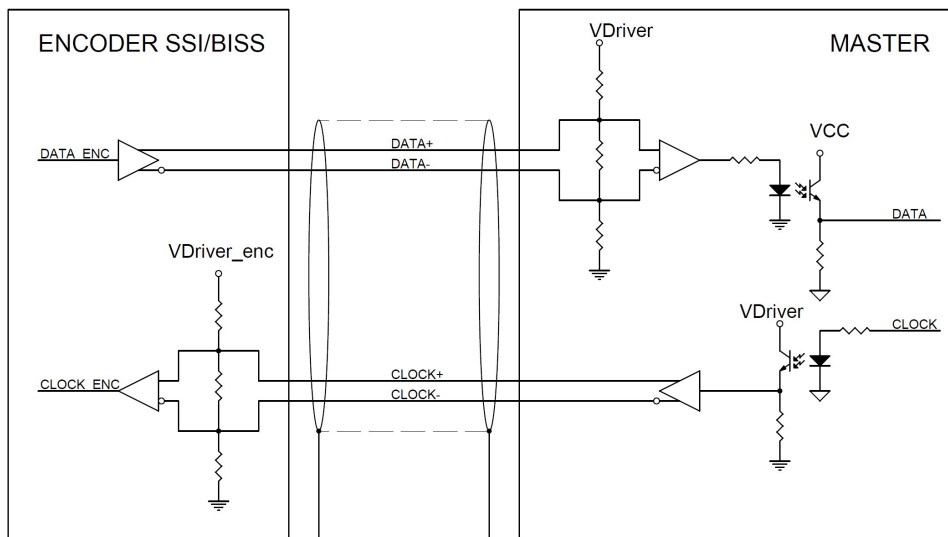

## 6 - 1Vpp sine/cosine output signals

A (COSINE) and B (SINE) signals are to be intended with CW rotation as viewed in the Figure in the "4.6 Counting direction input" section on page 10. The encoder provides 2,048 sinusoidal waves per mechanical revolution with amplitude 1Vpp. 1Vpp output level results from differential signals detection. The frequency of output signals is proportional to the rotational speed of the encoder.

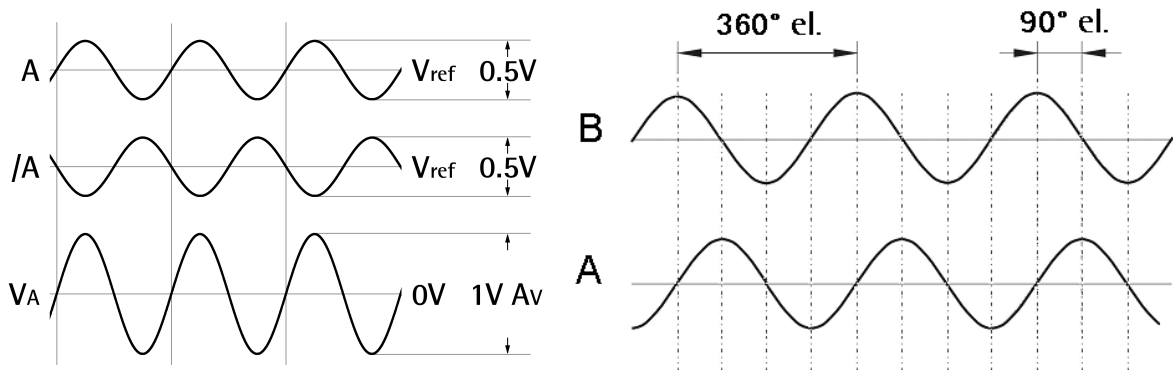

### 6.1 Output signals voltage level

The voltage level refers to the differential value between normal and inverted signal (differential).

### Recommended input circuit

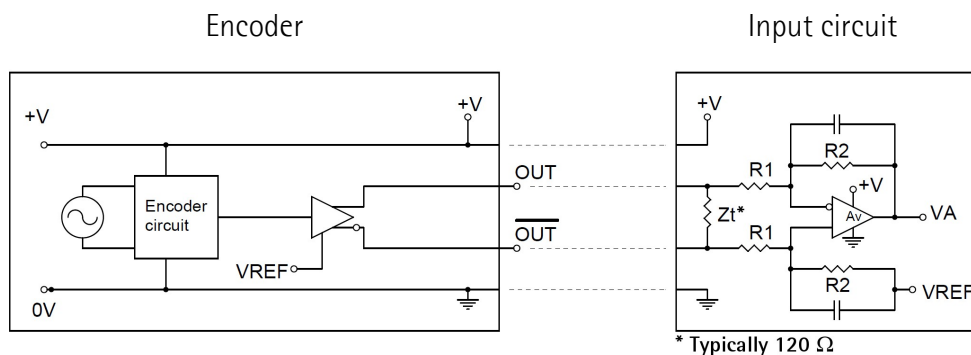

$$V_{REF} = 2.5V \pm 0.5V$$

$$V_A = 1V_{pp} * A_v$$

$$A_v = R_2 / R_1$$

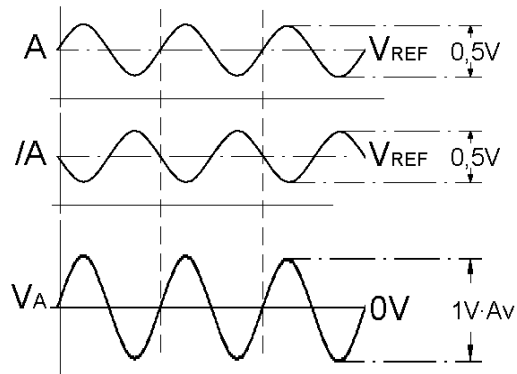

## 7 - Default parameters list

Parameters list	Default value *		
<b>Command</b>	00		
<b>Configuration</b>	20		
Bit 0 not used	0		
Bit 1 Set preset / offset	0 = Preset		
Bit 2 Enable preset / offset	0 = Enable		
Bit 3 not used	0		
Bit 4 not used	0		
Bit 5 Output code	1 = Binary		
Bit 6 Code sequence	0 = CW		
Bit 7 not used	0		
<b>Counts per revolution</b>	04 00 00 for HSx58x 01 00 00 for HMx58x		
<b>Number of revolutions</b>	00 01 for HSx58x 40 00 for HMx58x		
<b>Preset / Offset</b>	00 00 00 00		

\* All values are expressed in hexadecimal notation.

This page intentionally left blank

This page intentionally left blank

Document release	Release date	Description	HW	SW	File version
1.0	12.12.2008	First issue	-	-	-
1.1	03.09.2009	Section "5.5 Used registers" updated	-	-	-
1.2	14.10.2010	Section "4 - Electrical connections" updated	-	-	-
1.3	28.02.2020	General review	-	-	-



This device is to be supplied by a Class 2 Circuit or Low-Voltage Limited Energy or Energy Source not exceeding 30 Vdc. Refer to the order code for supply voltage rate.

Ce dispositif doit être alimenté par un circuit de Classe 2 ou à très basse tension ou bien en appliquant une tension maxi de 30Vcc. Voir le code de commande pour la tension d'alimentation.



Dispose separately

# lika

**Lika Electronic**

Via S. Lorenzo, 25 • 36010 Carrè (VI) • Italy

Tel. +39 0445 806600

Fax +39 0445 806699



info@lika.biz • www.lika.biz